

# **THE NORTH AMERICAN BANDERS' MANUAL FOR HUMMINGBIRDS**



**Stephen M. Russell and Ruth O. Russell**

Tucson, Arizona

Revised October 2019

**Jessica Pollock and Anthony Hill**, Editors  
Boise, Idaho and South Hadley, Massachusetts

**A product of the  
NORTH AMERICAN BANDING COUNCIL  
PUBLICATIONS COMMITTEE**

THE NORTH AMERICAN BANDERS' MANUAL FOR BANDING HUMMINGBIRDS  
Copyright © 2019 by Stephen M. Russell, Ruth O. Russell, Jessica Pollock, and Anthony Hill  
The North American Banding Council  
P.O. Box 1346  
Point Reyes Station, California 94956-1346 U.S.A.  
<http://www.nabanding.net/>  
All rights reserved.  
Reproduction for educational purposes permitted.

## Table of Contents

PREFACE.....	5
ACKNOWLEDGMENTS.....	5
1. INTRODUCTION.....	5
2. THE BANDER’S CODE OF ETHICS .....	6
3. CRITERIA FOR BECOMING A HUMMINGBIRD BANDER .....	7
3.1. Expectations.....	7
3.2. Training Opportunities.....	7
3.3. Federal Permits .....	7
3.4. State, Provincial and Territorial Permits .....	8
3.5. Other permits.....	8
3.6. NABC Certification .....	8
4. BAND MAKING AND BAND STORAGE.....	9
4.1. Ordering Bands.....	9
4.2. Cutting sheets of bands into strips .....	9
4.3. Edge preparation.....	9
4.4. Cutting individual bands from strips .....	10
4.5. Shaping bands.....	12
4.6. Storing prepared bands .....	13
5. CAPTURE METHODS (TRAPS).....	14
5.1. Portable Drop-door Cage Trap .....	14
5.2. Round Sliding-door Cage Trap (“Cartwright” trap) .....	16
5.3. Collapsible Cage-wire Trap (“Sargent” Trap) .....	16
5.4. Open-sided, Collapsible Netting Trap (“Hall Trap, “Bonnet” Trap).....	17
5.5. Collapsible Netting (“Dawkins”) Trap .....	18
5.6. Mist Net Trap (“Russell” Trap) .....	19
5.7. Modified Mist Net Trap.....	20
5.8. Mist Nets.....	20
5.9. Hummingbird Feeders for Trapping.....	21
6. HANDLING, HOLDS, AND RESTRAINTS.....	22
6.1. Handling of Hummingbirds.....	22
6.2. Holds.....	22
6.2.1. Fingertip Hold.....	22
6.2.2. Reverse Fingertip Hold.....	23
6.2.3. Hummingbird Banders’ Hold .....	23
6.3. RESTRAINTS .....	25
6.3.1. Holding Bags .....	25
6.3.2. Stocking Toe Hammock .....	26
6.3.3. Stocking Toe Cocoon .....	27
6.3.4. Casting Jacket .....	27
7. STRESS, INJURIES, DISEASE, and EUTHANASIA .....	29
7.1. Signs of Distress .....	29
7.2. Duration of Restraint .....	30
7.3. Injuries and Disease.....	30
7.3.1. Zoonotic Diseases.....	30
7.3.2. Sanitary procedures for cleaning restraints and tools.....	31
7.4. Treatment/Supportive Care.....	31
7.5. Death of a Bird.....	32

7.6 Euthanizing a Bird .....	32
8. PROCESSING AND BANDING .....	33
8.1. Removing Hummingbirds from Nets and Traps .....	33
8.2. Species Identification.....	33
8.3. Banding a Hummingbird	
8.3.1. The banding locale.....	34
8.3.2. Restraining the bird.....	34
8.3.3. Determining band size .....	34
8.3.4. Applying the band.....	35
8.3.5. Verifying fit of the band .....	36
8.3.6. Removing a band .....	36
8.4. Data Collection and Measurements .....	36
8.4.1. Wing .....	37
8.4.2. Tail.....	37
8.4.3. Exposed culmen .....	37
8.5 Other characteristics	
8.5.1. Bill corrugations .....	39
8.5.2. Iridescence in gorget and crown .....	40
8.5.3. Feather shape and pattern .....	40
8.5.4. Rectrix color.....	40
8.5.5. Cloacal protuberance .....	40
8.5.6. Brood patch.....	40
8.5.7. Skull ossification/pneumatization.....	41
8.5.8. Body mass (weight) .....	41
8.5.9. Other.....	41
8.6. Color Marking .....	41
8.7. External parasites.....	41
8.8. Recaptures and Caution with Recaptured Females .....	41
8.9. Banding nestlings.....	41
8.10. Feeding Hummingbirds while banding .....	42
8.11. Releasing.....	42
8.12. Documentation of Rarities.....	43
9. DATA MANAGEMENT .....	44
10. PUBLIC RELATIONS, EDUCATION .....	45
11. LITERATURE CITED AND SELECTED BIBLIOGRAPHY .....	45
APPENDICIES.....	47
Appendix A - DESIGNING A RESEARCH PROJECT.....	47
Appendix B - BANDING EQUIPMENT, SOURCES, SUPPLIERS .....	49
Appendix C - INSTRUCTIONS FOR BUILDING TRAPS, HOLDING CAGES, AND BAGS .....	59
Appendix D - BANDING ASSOCIATIONS AND MEETINGS .....	78
Appendix E - LONG-TERM CARE AND REHABILITATION OF HUMMINGBIRDS .....	78
Appendix F - SKILLS AND KNOWLEDGE EXPECTED OF HUMMINGBIRD BANDERS .....	79
Appendix G - AN INSTRUCTOR'S GUIDE TO TRAINING HUMMINGBIRD BANDERS .....	81
Appendix H - A KEY TO WESTERN HUMMINGBIRDS .....	82
Appendix I - THE NORTH AMERICAN BANDING COUNCIL.....	92
Appendix J - OPTIONAL FIELDS FOR CODING HUMMINGBIRD CHARACTERISTICS.....	92

## PREFACE

The purpose of this Banders' Manual for Hummingbirds is to provide information for the safe and productive banding of these small birds. This publication is an integral part of a library of publications by the North American Banding Council (NABC), including *The North American Banders' Study Guide*, *The Instructor's Guide to Training Passerine Bird Banders' in North America*, and taxon-specific manuals (e.g., landbirds, raptors, shorebirds, and waterfowl). These guides can be downloaded free of charge from the NABC website (<https://www.nabanding.net/other-publications/>) and most are in English, French, and Spanish. We trust that this guide will be useful for all banders of hummingbirds, current and prospective.

—Publications Committee of the North American Banding Council  
C. John Ralph, Chair

## ACKNOWLEDGMENTS

The authors of the first edition received substantial contributions from William Baltosser, Barbara Carlson, Rita Colwell, Maryann Danielson, Mary Gustafson, Jan Hall, Mike Hall, Karen Krebs, Brent Ortego, Robert Sargent, and Susan Wethington. Duane Berger, William Calder, Troy Gordon, Don Mitchell, Nancy Newfield, George West, Sheri Williamson, Tom Wood, Ellie Womack, and Robert Yunick reviewed the manuscript and provided helpful suggestions. Jane Church carefully edited an early draft. Jerome Jackson, C. John Ralph, Jared Verner, and Glen Woolfenden did final editing. Rita Colwell, Pam Ensign, and Mike Hall provided original illustrations. The banding skills and knowledge of hummingbird biology shared by these people form the basis for this manual and are reflected throughout. We deeply appreciate all of these contributions.

— Steve and Ruth Russell

The editors of the 2018 and 2019 revisions were fortunate to receive significant guidance and input from the following dedicated hummingbird banders: Ann Adams, Felicia Aragon, Cindy Cartwright, Lanny and Linda Chambers, Allen Chartier, Chris Clark, Sarahy Contreras-Martinez, Fred Dietrich, Fred and Tena Engelman, Susan Heath, Sara Hiebert Burch, David Inouye, Omar Larios, Katherine McLaughlin, Alison Moran, Kira Newcomb, Ann Nightingale, Sumita Prasad, Barbara Robinson, Lee Rogers, Lisa Roig, Josée Rousseau, Cynthia Routledge, Bob Sargent (deceased), Lisa Tell DVM, Ingrid Tello-López, Susan Wethington, Sheri Williamson, Tom Wood and Bob Yunick. Photographs are individually credited. The comments contributed by Bruce Peterjohn, Chief of the U.S. Bird Banding Lab and Lesley-Anne Howes of the Canadian Bird Banding Office are greatly appreciated.

— Jessica Pollock and Anthony Hill

## 1. INTRODUCTION

This Manual is intended to serve as a compendium of guidelines for safe hummingbird banding practices. It represents a compilation of many techniques developed by a variety of dedicated and experienced hummingbird banders in Canada, Mexico, and the United States. No attempt is made to designate a single method for a given task; rather the intent is to offer an array of best practices for the experienced bander to consult. It is advisable for new banders to continue using the methods they learn during training until they gain enough experience and knowledge to fully understand the implications of making changes. It is recognized that each bander will approach a bird in a slightly different way based on their experience and knowledge.

Hummingbirds are unique - noted for their small size, their prolonged hovering and backward flight, their wide range of breeding areas, including cold montane areas where their small size is a great thermal disadvantage, and their use of nectar energy sources. Hummingbird diversity, in part, reflects coevolution with their food plants. Although ornithologists have learned much about these birds using a variety of research tools, including banding, large gaps exist in our knowledge that could be filled with additional information from well-designed banding programs. These studies could lay the foundation necessary to establish conservation and management strategies for various species.

The North American Banding Council strongly encourages all banders to consider the usefulness of the information they gather, emphasizing the ultimate use of the data rather than its collection. Collecting sound data for scientific purposes, conservation, management, and publishing your results and/or making your data available to others should be the ultimate goal. If you are not part of an established research project, please consider sharing your data with such a program. Banders who are not part of an established research program can still make a valuable contribution to databases that scientists use for analysis, provided their banding data are accurate. Note that while we all submit our data to our countries' respective banding entity, neither the Canadian Bird Banding Office, nor the U. S. Bird Banding Lab employs biologists who analyze hummingbird data. We encourage you to standardize and share data with other banders and hummingbird researchers. Although hummingbird banding can be useful as an educational tool, that should not be its main purpose, as other methods are available that are less stressful to the birds. The hummingbird's welfare should always be the first consideration.

## 2. THE BANDER'S CODE OF ETHICS

1. Banders are responsible for the safety and welfare of the birds they study so that stress and risks of injury or death are minimized.  
Some basic rules:
  - handle each bird carefully, gently, quietly, with respect, and minimize handling time
  - capture and process only as many birds as you can safely handle
  - close traps or nets when predators are in the area
  - do not band in inclement weather
  - frequently assess the condition of traps and nets and repair them quickly
  - properly train and supervise students and assistants
  - check nets as frequently as conditions dictate
  - check traps as often as recommended for each trap type
  - properly close all traps and nets at the end of banding
  - do not leave traps or nets open and unattended
  - use the correct band size and banding pliers for each bird
  - treat any bird injuries humanely
2. Continually assess your own work to ensure that it is beyond reproach.
  - reassess methods if an injury or mortality occurs
  - ask for and accept constructive criticism from other banders
3. Offer honest and constructive assessment of the work of others to help maintain the highest standards possible.
  - publish innovations in banding, capture, and handling techniques
  - educate prospective banders and trainers
  - report any mishandling of birds to the bander-in-charge
  - if no improvement occurs, file a report with the banding office
4. Ensure that your data are accurate and complete, are submitted in timely fashion to the responsible agency or organization, and are appropriately used to advance valid scientific purposes.
5. Obtain prior permission to band on private property and on public lands where authorization is required.

Bird banding is used around the world as an important research tool. When used properly and skillfully, it is both safe and effective. The safety of banding depends on the use of proper techniques and equipment and on the expertise, alertness, and thoughtfulness of the bander. The Bander's Code of Ethics applies to every aspect of banding. The bander's essential responsibility is to the bird. Other things matter a great deal, but nothing matters so much as the health and welfare of the birds being studied. Every bander must strive to minimize stress placed upon birds and be prepared to accept advice or innovation that may help to achieve this goal. Methods should be examined to ensure that the handling time and types of data collected are not prejudicial to the bird's welfare. Banders must be prepared to streamline the procedures of the banding operation, either in response to adverse weather conditions or to reduce a backlog of unprocessed birds. If necessary, birds should be released unbanded, or the trapping devices should be temporarily closed. Banders **must not consider that some mortality is inevitable or acceptable in banding**. Every injury or mortality should result in a reassessment of your operation. Action is then needed to minimize the chance of repetition. The most salient responsibilities of a bander are summarized in the Banders' Code of Ethics, above.

Banders must ensure that their work is beyond reproach and assist fellow banders in maintaining the same high standards. Every bander has an obligation to upgrade standards by advising the Banding Offices of any difficulties encountered and to report innovations. Banders have other responsibilities too. Banders must submit data to the Banding Offices promptly, reply promptly to requests for information and maintain an accurate inventory of their band stocks. Banders who interact with the public also have an educational and scientific responsibility to make sure that banding operations are explained carefully and are justified and that the information presented to the public by the entire banding team is accurate and complete. Finally, banders banding on private property have a duty to obtain permission from landowners and to address their concerns.

### 3. CRITERIA FOR BECOMING A HUMMINGBIRD BANDER

#### 3.1. Expectations

Hummingbird banders should have no physical limitations that might prevent careful handling of these tiny birds. Excellent manual dexterity, steady hands, good vision, and infinite patience are required. The welfare of the birds must always be the primary concern. A bander who cannot clearly see these small birds with eyeglasses or a magnifying visor should not handle them, because the risk of injuring the bird is too high. The knowledge/skill requirements for a hummingbird bander are extensive, and difficult to summarize in one document, but a good starting point for potential banders' to review can be found at this link:

<http://www.nabanding.net/wp-content/uploads/2012/04/Hummingbird-reportcard.pdf> . Banders must also be able to produce proper bands that can be safely used on the birds, including cutting, sanding, shaping, and storing the bands. In the U.S., the required formal training course will meet this requirement. In Canada, banders should not recommend a new bander be permitted until they are certain they are competent and skilled at making bands. In Mexico, lead researchers of the Red de colibríes de México (Hummingbird Network of Mexico) control the band making and provide training to potential banders.

Persons who wish to band hummingbirds should be familiar with the contents of the Banders' Study Guide (<http://www.nabanding.net/other-publications/>). Banders should also be familiar with the North American Bird Banding Manual (<https://www.pwrc.usgs.gov/BBL/manual/>). The goal of this *North American Banders' Manual for Banding Hummingbirds* is to flesh out all safe techniques in further detail and emphasize special concerns involved in banding the world's smallest birds.

#### 3.2 Training Opportunities

Training and experience in banding passerines can be advantageous as they provide a basic understanding of data collection and reporting, bird handling, the use of mist nets, and stress in birds and how to avoid it, but this is not a prerequisite. To acquire the necessary skills and knowledge for hummingbirds, one must learn from a permitted and skilled hummingbird bander, who is willing to teach while conducting his or her own studies. While mentorship by a permitted hummingbird bander is an important aspect of the training process, by itself, this mentorship is not sufficient for obtaining authorization from the U.S. BBL, which requires a formal training course. While the BBL requires a formal training course, they do not formally sanction or endorse any course. A formal training course is not required for obtaining a banding permit in Canada or Mexico.

Trainers certified by the North American Banding Council (NABC) may occasionally offer workshops that provide a concentrated learning experience: <https://www.nabanding.net/nabc-training-sessions/>. The Hummingbird Monitoring Network provides a week-long training course annually in the autumn: <http://www.hummonnet.org/GetInvolved.html#events>. The BBL is deciding how new trainers can be brought in to satisfy the requirement for formal training. To be informed of other training opportunities as they arise, join a regional banding association, or monitor the "BIRDBAND" listserv group <http://www2004.lsoft.se/scripts/wl.exe?SL1=BIRDBAND&H=KSU.EDU>. Once you are a permitted hummingbird bander (Master or sub-permittee, consider joining the "HUMBAND" listserv, which is specifically for hummingbird banders to discuss techniques and share ideas. Send a request to join along with your sub-permit number, state/province where you are permitted to band FROM the email address you wish to use to post and receive messages from Humband. Send the request to [routledges@bellsouth.net](mailto:routledges@bellsouth.net) or [susan.heath888@gmail.com](mailto:susan.heath888@gmail.com). You will receive an email to confirm your request.

#### 3.3. Federal Permits

In the U.S. a federal Bird Banding Permit is required to band any migratory wild bird. In the U.S., permits are issued by the Bird Banding Laboratory (BBL): [https://www.usgs.gov/centers/pwrc/science/bird-banding-laboratory?qt-science\\_center\\_objects=0#qt-science\\_center\\_objects](https://www.usgs.gov/centers/pwrc/science/bird-banding-laboratory?qt-science_center_objects=0#qt-science_center_objects), a part of the United States Geological Survey (USGS). The application requests information and must include a cover letter specifying in detail the research goals. The applicant must demonstrate successful completion of a formal training for hummingbirds, that covers all aspects of hummingbird banding and band-making protocols in order to qualify to band this unique family of birds (see Section 3.2, above). Names and contact information for established banders who are familiar with the applicant's banding skills must be provided as well as the name of the person(s) who conducted the hummingbird training. Permission to band hummingbirds is requested in addition to any other group of birds that the permit may cover. Hummingbird bands will not be issued unless the prospective banders permit specifically includes hummingbirds. Reference should be made to the Banders' Study Guide for details regarding provisions associated with the permit.

In Canada, a scientific permit is required to capture and band hummingbirds. To obtain a Canadian permit, applicants must complete the bird banding permit application form and demonstrate that they have the training and experience to undertake their proposed activities including demonstrated competency in ethical capture and handling, bird identification, aging, sexing, banding and record keeping. Applicants must also submit a detailed scientific project description that outlines the study objectives and justifies the need to capture and band birds in Canada. A formal hummingbird training course is not required to obtain a permit. A Report on Applicant Qualifications form must be submitted from two permitted banders who are familiar with the applicant's abilities to undertake the proposed activities. These reports must be provided by a bander with a hummingbird endorsement on their permit. If the applicant is an NABC certified hummingbird bander, the certification qualifies as one report (see Section 3.6). If you already have a banding permit for other species, you need only one reference from a qualified bander with a hummingbird endorsement on their permit or

official NABC hummingbird certification. Any projects that include the use of auxiliary markers, biological collections, or veterinary procedures must submit an Animal Use Protocol and Animal Care Committee approval certificate. For more information please visit the Bird Banding Office Website: <https://www.canada.ca/en/environment-climate-change/services/bird-banding.html>

In Mexico, the “Secretaría de Medio Ambiente y Recursos Naturales” (SEMARNAT - Federal Agency), undersecretary of management for environmental protection “Dirección General de Vida Silvestre”, provides the license to collect wildlife for scientific and educational purposes (SEMARNAT09-049). This agency can authorize the banding permits, but may require an NABC training certificate be provided by the applicant. No animal care committee approvals are required.

### **3.4. State, Provincial and Territorial Permits**

In the U. S., the Federal Bird Banding Permit indicates the states where a bander is authorized to band, but the federal permit is not valid without a state permit, if one is required. The state of a bander’s residence is most often the only state listed on a permit. Persons seeking authority to band in two or more states must provide justification to the Bird Banding Laboratory. A bander involved in a research project that requires working in several states may be granted that authority. The bander must request banding permission from the appropriate state agency and each state sets its own requirements and fees for permits. Some states do not issue permits and others require a detailed application similar to the federal one. The state permit does not permit banding without the federal permit and is not issued until a federal permit has been granted. For state permit requirements, the agency that manages wildlife should be contacted with a request for regulations on collecting or banding permits and for permission to conduct banding activities on public lands. In Canada, provinces and territories have their own wildlife legislation. Please consult your local authority to ensure you have the appropriate permits to conduct your research. In Mexico, state permits are not required. However, see section 3.5 below.

### **3.5 Other permits**

If banding will take place in provincial or territorial parks, state parks, national parks, National Wildlife Areas, Migratory Bird Sanctuaries or other protected or regulated areas, it is the responsibility of the bander to acquire and possess the appropriate permissions.

### **3.6. NABC Certification**

The North American Banding Council (NABC) has developed bander certification programs to set standards for the knowledge, experience, and skills for banders. Certification is optional and is not a requirement for obtaining a federal or state banding permit in the U.S., Canada or Mexico. NABC certification is different from the U.S. requirement of a formal training course (it is an assessment, not formal training). Certification recognizes the bander’s accomplishments, shows a level of competency, and can help to demonstrate competence when submitting an application for a banding permit. Certification may open new opportunities for banding. A bander certified as a Trainer may be involved in NABC instructional programs and evaluate the competency of banders applying for certification, and may also attend the organization's annual meeting and contribute to the development of training and certification materials. Hummingbird banders are encouraged to seek NABC certification, which involves written testing and field evaluation, as tangible evidence of their expertise. Three levels of NABC certification are offered: Assistant, Bander, and Trainer. An Assistant is competent to handle and band birds under direct supervision of a qualified bander. A Bander is competent to (a) design and carry out meaningful studies involving the capturing, handling, identifying, ageing, sexing, banding, and measuring of birds, (b) record data, and (c) complete accurate and timely banding schedules. A Trainer is a Bander with exceptional experience, knowledge, skill, and demonstrated teaching ability. Occasionally certification sessions are offered:

<https://www.nabanding.net/upcoming-sessions/>. The Association of Field Ornithologists, along with NABC, sometimes offer small grants to support travel and visa expenses for interns at any North American banding program that offer certification. The grants can also be used to support NABC certification sessions held in a Latin American or Caribbean country. Applications and information are here: <http://www.nabanding.net/pequenas-subsenciones-de-certificacion-certification-small-grants/>.



## 4. BAND MAKING AND BAND STORAGE

### 4.1. Ordering Bands

Hummingbird bands are provided free of charge by the Bird Banding Lab (BBL - U.S.) and the Bird Banding Office (BBO - Canada), and may be ordered only by master permittees who have permission to band hummingbirds. Sub-permittees must obtain bands through their master permit holder. Hummingbird banders in Mexico typically coordinate with US banders to obtain bands. Bands are printed on sheets of aluminum alloy approximately 10.2 x 15.2 cm, each imprinted with 300 bands (Figure 1). Note: U.S. banders currently have the option of ordering their bands pre-cut into strips of 10 by the BBL, but only if the BBL has enough time and personnel to complete the request. As is the case with all bands, hummingbird banders have the responsibility of inspecting newly-issued bands on receipt to ensure that they are properly cut, specifically with reference to strip height, so they can safely be applied to birds. Some banders may prefer to cut ('strip') bands themselves to ensure uniformity, and so should order them in the appropriate configuration. There are no plans for any banding agency to provide pre-formed hummingbird bands, so learning how to make bands is a critical step to becoming a permitted hummingbird bander.

Figure 1. An uncut sheet of hummingbird bands (photo: Lanny Chambers).

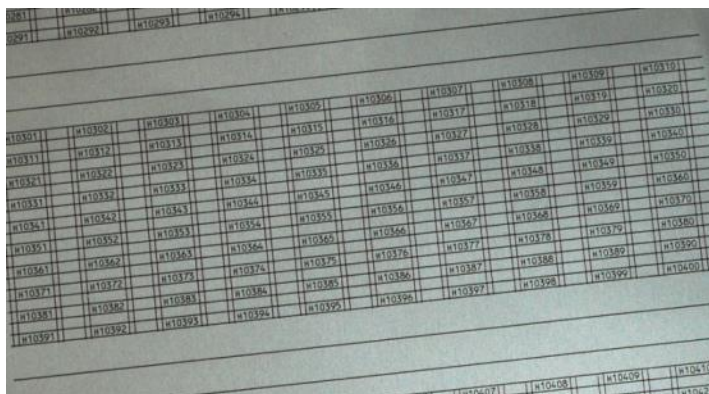

### 4.2 Cutting sheets of bands into strips

Bands are printed in rows, with blank space between each row. Each band has a unique combination of a letter (representing the 4-digit prefix), followed by the five-numeral suffix. The rows must be cut ('stripped') just inside the lines to form strips with ten bands printed on each (Figure 2). **Please note, stripping bands with scissors is no longer permitted.** Stripping bands with a jeweler's (bench) shear or shear brake is the currently approved method. A bench shear, used by silversmiths, is a precise tool that can be used to cut the sheets of bands into strips. Many banders report that the strips need very little smoothing with this method. An alternative device that has also proven useful is the **Mini Shear Brake** - see [Appendix B, Band Stripping Tool](#). The line itself must not be left on the band, as this may result in a band so tall that it could cut into the tarsus or toes of a perched bird. The edges of the strips must be smoothed at this stage (see [Section 4.3](#) below). Cutting the sheet into strips is difficult. The strips of metal tend to curl and may have sharp edges that must be smoothed before use. Band strips cut wider than 1.5 mm will not fit into the Slotted Band Cutter (Figure 3) that aids in cutting individual bands to specific lengths. The waste stock that is left between rows of bands should be saved to use for practice making bands.

Figure 2. A strip of 10 bands (photo: Heather Hayes).

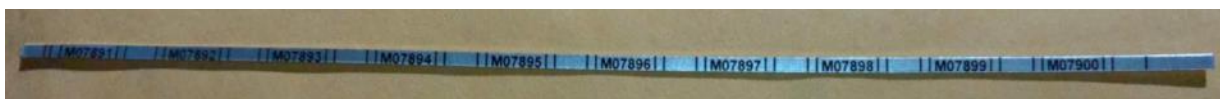

### 4.3 Edge preparation

Sharp, clean blades on the bench shear are the first and most critical step in the process of producing smooth, safe edges on band strips. Regardless of the cutting method, all edges of the strips should be filed or sanded smooth. Black "wet" type (carborundum) sandpaper, starting with extra fine grade (400 to 600 grit) and finishing with ultra-fine (1000 to 2000 grit), works well and can be found in most hardware stores. Be aware that grit numbers are not standardized and vary among manufacturers; with experience, the bander can tell by the amount of surface texture the paper's suitability for smoothing or finishing. An inexpensive and convenient (though less durable) alternative is multi-grit foam nail blocks, available in drug and beauty supply stores; finer grit designated for "smoothing" and "polishing" or "shining" nails are safe for band making. These have the added advantage of conforming to the strip as it is drawn across the sanding surface. If there is any doubt, the band should be drawn through tightly-pinched, uncalloused fingers to check for sharp edges or burrs.

#### 4.4 Cutting individual bands from strips

Strips should be cut into individual bands of the length needed with the Slotted Band Cutter (Figure 3) that will ensure the ends of the band are square. Both adjustable and fixed length band cutting tools are commercially available which cut bands to precise lengths ([Appendix B](#)). Alternatively, high quality metal shears can be used ([Appendix B](#)). Band lengths needed will depend on what species are being banded (Figure 4 and Table 1). Any cutting procedure must also include a measuring step to confirm that the band(s) are cut to the appropriate length. The length of unshaped, flat bands should measure within -0.01 or +0.05 mm of the specified length.

Figure 3. Cutting an individual band – the slotted band cutter (left) and field cutter (right) (photos: Lee Rogers).



Figure 4. Cutting lines for four band sizes.

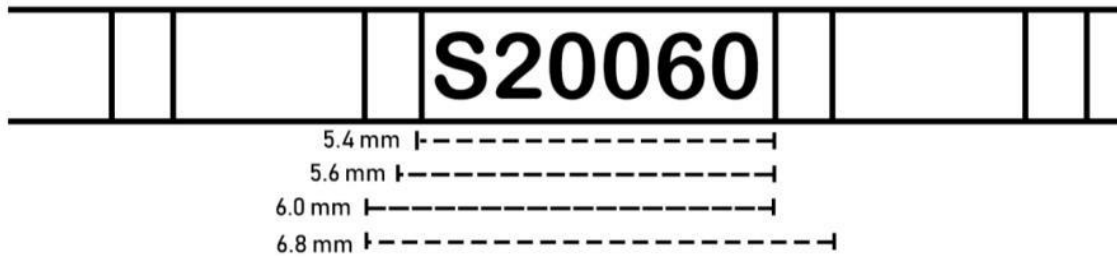

Table 1. Band size recommendations (see Determining band size, section 8.3.3) for hummingbirds by species and sex.

For full names of species codes, see: <https://www.pwrc.usgs.gov/bbl/MANUAL/speciest.cfm>

Species	Sex	Recommended Band Size	Count of birds used for analysis	Avg. of TARSUS	Min. of TARSUS	Max. of TARSUS	Avg. of BAND	Min. of BAND	Max. of BAND	Comments
ALHU	F	E (5.8 mm)	28	E	D	F	E	D	F	Significant swelling in females occur breeding season
ALHU	M	D (5.4 mm)	74	D	B	E	D	C	E	
ANHU	F	G (6.2 mm)	4,644	F	C	H	F	D	H	
ANHU	M	F (6.0 mm)	3,219	F	C	G	F	D	L	
BBLH	F	G (6.2 mm)	3,922	F	C	G	F	E	G	Based on HMN survivorship analyses
BBLH	M	F (6.0 mm)	8,026	E	C	H	E	D	H	Based on HMN survivorship analyses, Bands will slide over the tarsal joint
BCHU	F	G (6.2 mm)	23,255	F	B	J	F	C	J	Band size significantly influences survivorship and this result is independent of location
BCHU	M	E (5.8 mm)	17,655	D	B	G	D	C	G	Based on HMN survivorship analyses
BEHU	F	H (6.4 mm)	456	H	G	I	H	H	L	Tarsus measurement equals band size for this species, no rounding up
BEHU	M	G (6.2 mm)	730	G	E	H	G	F	L	Tarsus measurement equals band size for this species, no rounding up
BLUH	F	N (7.6 mm)	423	K	I	N	N	L	O	
BLUH	M	N (7.6 mm)	835	L	I	O	N	L	O	
BTLH	F	E or F (5.8 or 6.0 mm)	12,200	E	B	H	F	C	N	Tarsus measurement equals band size for this species, no rounding up
BTLH	M	D or E (5.6 or 5.8 mm)	6,866	D	A	H	E	C	H	Tarsus measurement equals band size for this species, no rounding up
CAHU	F	D (5.6 mm)	1,247	D	B	G	D	B	G	
CAHU	M	C (5.4 mm)	945	C	A	E	C	B	F	
COHU	F	D (5.6 mm)	414	D	B	G	D	C	G	
COHU	M	C (5.4 mm)	219	C	B	E	D	C	F	
LUHU	F	F (6.0 mm)	26	F	E	G	F	E	G	
LUHU	M	D (5.6 mm)	51	E	C	F	E	C	F	
RIHU	F	N (7.6 mm)	2,469	J	G	O	M	J	O	Tarsus measurement + 3 sizes is best for band size
RIHU	M	L or N (7.2 or 7.6 mm)	5,555	J	G	N	M	J	O	Tarsus measurement + 3 sizes is best for band size
PCST	F	TBD	1	K	K	K	L	L	L	
PCST	U	TBD	1	L	L	L	N	N	N	
RUHU	F	E (5.8 mm)	6,731	D	A	G	E	C	H	Significant swelling during breeding. More information needed
RUHU	M	D (5.6 mm)	5,055	D	A	G	D	C	H	
RTHU	M	C (5.4 mm)	>350	C	A	D	C	C	D	Tarsus measurement equals band size for males, no rounding up
RTHU	F	D (5.6 mm)	>350	F	D	G	D	D	E	Band size is smaller than size indicated by tarsus gauge
VCHU	F	J (6.8 mm)	31	I	G	J	J	J	J	
VCHU	U	J (6.8 mm)	165	I	G	J	J	H	L	
WEHU	F	G (6.2 mm)	83	F	F	J	F	F	G	Tarsus measurement equals band size for this species, no rounding up
WEHU	M	F (6.0 mm)	41	F	E	F	F	F	F	Tarsus measurement equals band size for this species, no rounding up

#### 4.5 Shaping bands

This is a critically important step. Sometimes, even the best-made band proves to be unsuitable. Great care must be taken to ensure that bands will form a cylinder as evenly and squarely as possible to create a seamless butt joint with no sharp edges that might injure the bird. When cutting and shaping individual bands, work should be performed in a well-lit area where there is great visibility and a clean surface. Working on a tray or towel ensures that dropped bands are more likely to be recovered.

Professional band-shaping tools were formerly available from the late Roger MacDonald and currently from Lee Rogers (see [Appendix B](#)). Banders are not encouraged to make their own tools because bands must be made with great precision to avoid injuring the birds. For band shaping, the following tools are needed:

- (1) Metal shaping jigs are available from Lee Rogers for both closed cylinder or open 'C' shaped bands (Figure 5)- the Small 5-pin Band Former for sizes 5.4mm thru 6.2mm (2mm increments) and the Large 5-pin Band Former for sizes 6.4mm thru 7.9mm (4mm increments). These tools shape bands in perfect cylinders with their ends smoothly butted. With care, all sizes can be shaped.
- (2) Small forceps to aid in forming the band around the shaping pins. Care must be taken to ensure that the soft aluminum of the band is not damaged by the hard edges or teeth of the forceps. Forceps with serrations on the inside surfaces should be avoided.
- (3) Band storage device or medium (storage pins, wire or safety pin).

After the band sheet has been cut, the strips smoothed, and individual bands cut, band shaping jig tools should be used to shape individual bands into either closed cylinders or an Open 'C'. The ends of each band must be square cut and remain square after smoothing. Both ends and sides of the band must be checked to ensure that no burrs are present. To shape a band into a closed ring with a Band Former it should be placed on edge, band numbers to the outside, on the side of the appropriate pin (Figure 5A). The right shaper arm is pressed tightly against the band (Figure 5B) - left-handed persons should reverse this entire procedure. Next, the right shaper arm is held against the band and the forceps are placed flat on the shaper surface. Roll, do not pinch, the ends of the band around the pin with the flat of the tweezers or a wooden stick to a partially closed position (Figure 5C). The left shaper arm is then firmly pushed against the pin to complete the shaping (Figure 5D). The band should now be completely wrapped around the small pin (Figure 5E). The two butts should be aligned top to bottom while still on the shaping pin by gently pushing down on the upper edge with a fingernail, forceps, or tweezers.

Figure 5. (A) A band-forming tool; (B) Unshaped band set against post on; (C) A half-shaped band; (D) Blunt-nosed forceps gently used to nudge band ends around post; (E) Jig arm used to complete band; and (F) Completed band (photos: Lee Rogers).

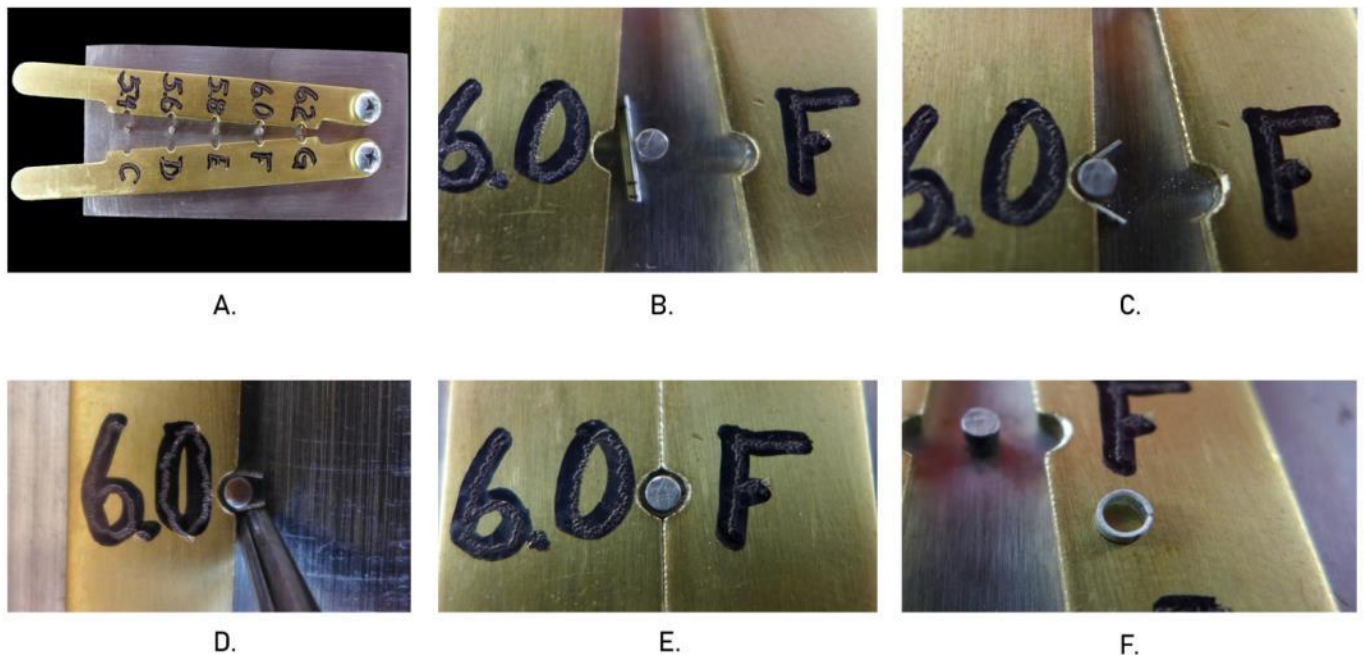

When forming bands into the Open 'C' shape use a similar technique as above. Place the band, numbers out, on the left side of the pin and close the left lever. Roll, do not pinch, the ends of the band around the pin with the flat of the tweezers to partially close. Rotate the band opening 90 degrees such that the opening points up toward the top of the jig. Close both levers around the band to form the Open 'C'. To ensure that the band is perfectly symmetrical, lift the band off the pin, turn it upside down, place it back on the pin, and close both handles again. Put the band on a Band Storage Pin or other medium. When bands are on storage pins line up band openings and visually inspect that ends are even.

If bands are stored closed, they must be carefully examined and any necessary adjustments made before placing them on a pin or wire. For use, closed bands must be very carefully opened to preserve the correct open-C shape that is important for fit of the band in the pliers opening. A large eye tapestry needle (or similar) may be used to open bands into a flat-backed “C” that conforms to the shape of the halves of the plier hole by slipping the band over the eye, with care taken to avoid opening the band any more than necessary to clear the hole in the pliers when seated. The band must be properly seated in the hole of the pliers or it may deform when closing.

Banders using more than one band size can cut each one individually to fit. If many birds of different sizes are being banded, however, it is best to make the sizes needed in lots of 10 to 50, depending on anticipated usage. These bands can then be stored separately; this method is more likely to result in bands of higher quality. When small numbers of certain sizes are needed, these can be made individually as needed from strips set aside for that purpose or pre-made in small quantities.

#### 4.6 Storing prepared bands

After shaping and smoothing, bands may be stored closed in sequence on a wire, large safety pin, or storage pins (Figure 17A). Commercially available products such as stitch holders and diaper pins are excellent for closed bands; the plastic basal portion can be labeled with a permanent marking pen. Closed bands are easily opened using the pins on the banding pliers or a large eye tapestry needle (see [Appendix B](#)). Bands formed in an Open ‘C’ can be stored on pieces of numbered drill rod (Storage Pins) that is the same diameter as the forming pin in the 5-pin Band Formers. Each Band Storage Pin (see [Appendix B](#)) will hold 50 bands and has removable earring nut clips to secure the ends and provide easy access. Do not store bands in beeswax or on tape – this method is no longer recommended as pieces of beeswax can get caught between the band and the hummingbird’s leg and tape can leave a residue.

Figure 6. (A) Open bands on storage pins; (B) Closed bands brass wire; (B) Closed bands on diaper pins; and (C) Closed bands on stitch holders (photos: Lee Rogers).

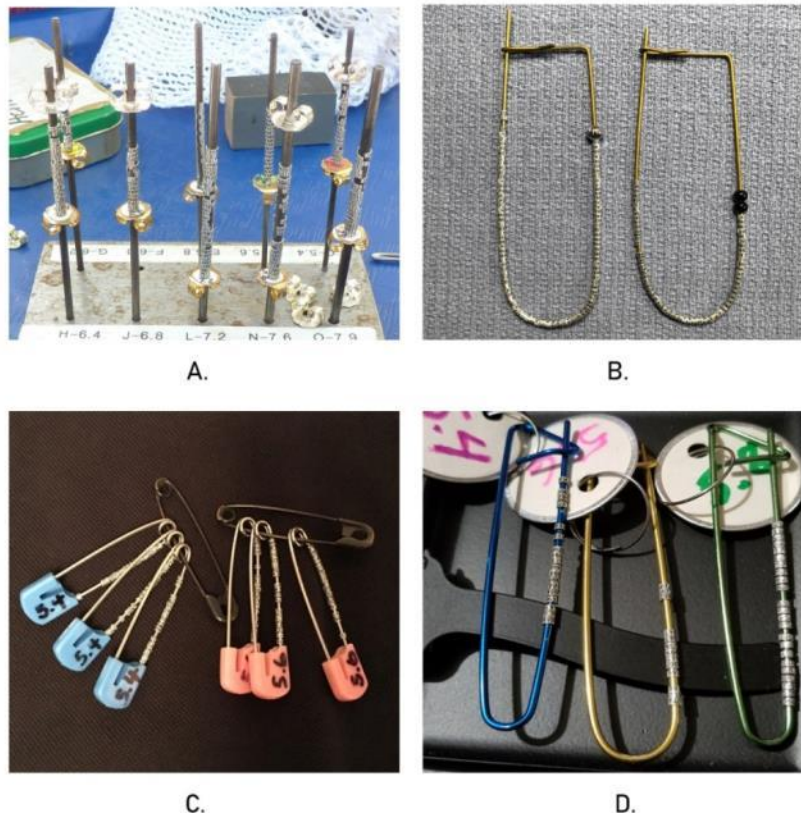

## 5. CAPTURE METHODS (TRAPS)

Table 2. Quick reference of some common trap choices (rated on a scale of 1-5, with 5 being better).

Trap Type	Ease of Construction	Cost	Portability	Bird Safety	Adaptable to conditions *	Ease of extraction
Portable Drop-door Cage Trap	2	4	4	3	3	4
Open-sided, Collapsible Netting Trap ("Hall Trap, "Bonnet" Trap)	1	1	5	4	4	4
Collapsible Netting ("Dawkins") Trap	5	5	5	5	4	4
Mist Net Trap ("Russell" Trap)	4	4	4	3	3	1

\*Wind, Rain, Selective Capture, Constant attention

### 5.1. Portable Drop-door Cage Trap

#### 5.1.1. Design

Successful hummingbird cage traps come in a variety of shapes, styles, and sizes and take advantage of a hummingbird's attraction to a food source, usually a nectar feeder. Birds will key in on the exact location of feeder, so the trap is set up with a feeder inside. In many instances, the most common choice is a drop-door that is activated when the bander manually releases a line, or a radio controlled or electronic release device. The doors on some cages are hinged at the top to swing down and cover the door opening. Others have a slide-type door that drops straight down over the opening. The trap should be large enough to hold a feeder placed far enough from the entrance to allow the door to be shut before the bird can escape. Most cages are made from metal hardware cloth or cage wire; others include a wooden, coated metal or PVC frame covered with netting or similar transparent material. The trap must be small enough for the trapper to reach all areas inside to grasp the bird. Many hummingbird banders build their own traps, with individual variations. See [Appendix C.1.](#) for directions for constructing a basic trap.

#### 5.1.2. Use

These and other traps are most effective when placed where feeders have been in use for some time. This pre-baiting is effective because hummingbirds return to the exact sites where they have fed before. A drop-door trap may be kept permanently baited with a feeder and the drop-door very securely latched or wired open when not in use. Many hummingbirds tend to fly up when startled so an open door on the top of a cage trap is recommended during pre-baiting. All doors other than the 'main' one are closed for trapping operations.

#### 5.1.3. Concerns/cautions

The trigger line should be released only when the bird is well within the trap, and preferably feeding. Hummingbird reaction times are extremely fast so the risk of the falling door hitting the bird must always be a concern. Traps should be designed so that birds caught by the door are not injured. The 'swing' style door (Figure 7) gains speed as the door drops (think of crack-the-whip as a child) and has the potential to knock birds in flight out of the air, damage bills and wings, or trap the hummingbird between the door and the door frame, but this is uncommon. It is important to hang the feeder above the door inside the trap and make sure the bird is feeding before tripping the line. A high ceiling in the trap also helps avoid escapees or injury. The 'slide' style door (Figure 8) closes a little more slowly and birds tend to fly up and away from it, more so than the 'swing' style door, possibly due to the sound of the door sliding. It is still possible for a bird to be trapped between the bottom of the door and the bottom of the door opening. Sponge foam or wide elastic placed across the bottom of the door opening prevents the bird from being trapped between two hard surfaces and provides some padding to prevent injuries (Figure 9).

Birds sometimes attempt to fly out where there is no exit on pre-baited traps. Doors left open on the top and the side of the trap should solve this problem, but if this persists when active trapping is not in progress and all doors are open, the trap should be closed and the feeder hung outside. Observe birds in newly-placed, open traps to be sure they do not exhaust themselves in a futile effort to escape.

Figure 7. A “swing” style door cage trap (photo: James Bell).



Figure 8. A “slide” style door cage trap (photo: Lee Rogers).



Figure 9. Detail of the “slide” style door cage trap, with added padding at bottom. Note that there is a built-in gap at the bottom of the door travel that is closed by a piece of nylon stocking stretched over 2 small bungees (photo: Anthony Hill).



## 5.2 Round Sliding-door Cage Trap (“Cartwright” trap)

### 5.2.1 Design

This trap was designed based on reports from other banders that hummingbirds were more likely to find the door on a round trap (Figure 10). Hummingbirds had been observed flying down one side of square traps and leaving the trapping area instead of continuing around the corner to look for the door. With a round trap, hummingbirds continue circling the trap until they find the door. This trap is simple to make and requires much less cutting and clamping to build than a traditional square trap. The outer frame is a re-purposed ‘pet-store’ style bird cage lined with ¼” (about 6 mm) hardware cloth or mesh. The trap can be built out of hardware cloth without the metal frame by bending a sheet of ¼” hardware cloth into a cylinder with a diameter of 18-24”/45-60 cm. The diameter will depend on the size of the trapper and their ability to reach all areas within the trap to grasp the bird. The curved door is a ‘slide’ style fastened to metal coat hangers for smooth movement. Sponge is secured where the door meets the bottom of the opening to prevent the bird from being trapped between two hard surfaces and provides some ‘give’ to prevent injuries or squeezing the hummingbird. The hinged bottom panel makes it much easier to place any sized feeder inside. [See Appendix C.2.](#)

### 5.2.2 Use

This trap can be used in the same ways as other cage traps. The round shape prevents hummingbirds from reaching a corner and continuing in a straight line away from the trap instead of continuing around to the door. The entire bottom opens to allow the bander to use the host feeder regardless of its size, style or weight. Like other heavy cage traps, this trap style is stable in the wind, it allows the bander to clearly see if the hummingbird is inside the trap or not (compare to Hall trap when it’s not always easy to tell), the hummingbird has a smaller opening for escape as the trap closes (as opposed to the full 360 degrees on a Hall trap and one open side on the Russell trap), and once the door is closed the hummingbird cannot escape (compare to the Dawkins/ trap). If preferred, the sliding door can easily be secured in the open position to use the trap passively like a Dawkins/Collapsible Mesh trap. The entire cage can be taken down to readily transport the bird to the banding area and can be set back up again within minutes.

### 5.2.3 Concerns/cautions

The trap should not be used without sponge foam or similar material placed across the bottom of the door opening. If this trap is used for pre-baiting with the door secured open, it should be monitored to ensure birds do not exhaust themselves trying to find their way out. If this occurs, the trap should be closed and the feeder hung just outside the door.

Figure 10 – Round sliding-door cage trap (photo: Cindy Cartwright).



## 5.3 Collapsible Cage-wire Trap (“Sargent” Trap)

### 5.3.1 Design

This is essentially a modification of a standard Drop-Door Trap and may be modified to make a shorter unit for ease of transport. It is made from 1.0 x 0.5 inch (2.5 x 1.3 cm) galvanized cage wire, is 17 inches (42.5 cm) square and stands 36 inches (90 cm) tall (Figure 11). This is a fold-up design and the trap may be either suspended or placed on a flat surface. See [Appendix C.3](#) for instructions.



### 5.3.2 Use

This trap can be used in the same ways as other traps, but the collapsible feature makes it easy to transport.

### 5.3.3 Concerns/Caution

Along with the concerns mentioned for other traps, it is important to make sure this trap is properly secured when set up to avoid collapse, causing possible injury to hummingbirds while in use.

Figure 11. The collapsible cage-wire (Sargent) trap - sides are held together with twist ties (or similar) to allow the unit to be stored flat.

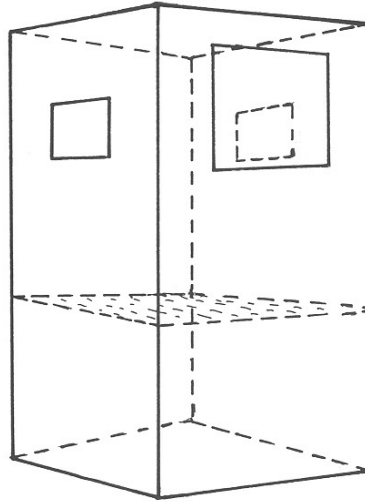

## 5.4. Open-sided, Collapsible Netting Trap ("Hall Trap," "Bonnet" Trap)

### 5.4.1 Design

The outside of this cylindrical hanging trap (Figure 12) is made of netting that falls to the base when the trap is triggered. The frame is constructed of PVC tubing and glued fittings; the vertical supports are flexible tubing, which enable the trap to collapse and be stored in a relatively flat state and is very portable. The trap is time consuming to make but productive, perhaps because it is open all around. Red netting is not required. Most banders use white netting.

### 5.4.2 Use

This trap is effective in situations where birds avoid cage-wire traps or where a dominant bird prevents others from entering the door of other trap styles because it is open all around. It is also effective for pre-baiting by hanging a partially constructed trap (frame only, no curtain) to allow birds to become accustomed to approaching a feeder with an object above their heads. When in use, open the trap 1/3 to 1/2 way as in Figure 12. If the netting is raised completely open, the "drop" time is too long, and birds can escape.

### 5.4.3 Concerns/Cautions

It can be difficult to tell if a bird is fully inside the trap or just on the edge. When this happens, the weight that pulls the curtain down can sometimes hit hummingbirds hovering along the edge, possibly causing injury (but see Taylor and Rogers variants). Trap design can be modified to eliminate this risk by having a soft lower portion of the curtain. And in some locations, more birds than can be processed in a timely manner are caught by this method. Note the guidelines for the construction of this trap ([Appendix C.4](#)) include lead fishing weights, which can sometimes pin a bird unintentionally. See the Taylor and Rogers variations for options to eliminate this potential hazard

Figure 12. Open-sided, collapsible netting trap - Rogers Variant (photo: Lee Rogers).



## 5.5 Collapsible Netting (“Dawkins”) Trap

### 5.5.1 Design

This trap (Figure 13) is similar in design to the cage traps described above and operates on the same general principle, except that the door does not close. The collapsible design makes it easy to carry multiple traps stacked on top of each other. Ten or more traps of this style can be stored in the same space as a single cage-wire trap. Materials list and instructions for building and materials list may be found in [Appendix C.5](#).

### 5.5.2. Use

The trap should be hung in the chosen location and the feeder inserted via the overlap on the side. Feeders without T-style perches are much easier to use with this trap. A cord with hooks on either ends, or similar arrangement, should be used to hang the feeder inside the trap. The cord is threaded through the top of the trap and attached to one of the metal bars. Feeder ports should be at the level of the opening so that hummingbirds can find their way into the trap. They will normally circle around outside the trap at the feeder port level until they find the opening. Some banders add a short piece of fluorescent pink flagging (a.k.a. surveyor's tape) through the mesh at the bottom of the opening. Many birds will zoom right up to it, see the feeder through the doorway, and then fly in. When frightened, birds usually fly to the top looking for a way out. To minimize the chances of escape, birds should be removed through the door rather than the overlap on the side.

### 5.5.3 Cautions

Hummingbirds can easily escape through the overlap if it is not secured flat or if the netting is not overlapped enough. The overlap should be checked each time the trap is hung to ensure there is no open gap.

Figure 13. Collapsible netting (Dawkins) trap – the entire trap and a close-up of the door opening (photos: Anthony Hill)



## 5.6. Mist Net Trap ("Russell" Trap)

### 5.6.1. Design

This trap, which incorporates a 6-m tethered net with a fine mesh (24 mm), is a modification of a trap used by David and Linda Ferry in the 1980s (Figure 14). It is used where hummingbirds are attracted to feeders and is very effective where large numbers of birds are present. The trap consists of two 6-m nets, or one 3-m and one 6-m net, one set up on poles in a  $\square$  shape with one side open. The second net is used as a top, forming a covered, walk-in enclosure. A feeder is hung on a pole just inside the open end; one or two additional feeders may be hung toward the back. It is often helpful if the entrance feeder is empty to help lure the birds deeper into the trap. The trap uses a catcher, who watches the trap and ensures that birds are inside the trap. See guidelines for the construction of this trap ([Appendix C.6](#)).

### 5.6.2. Use

The trap is most effective at sites that have been pre-baited with sugar solution in feeders for several days. When birds are to be captured, position the trap around the feeders, or very close to them, and face the open end where it is convenient for the catcher to wait about 8-10 m away. Ideally, the back of the trap would be in the direction of normal flight to cover. When a bird flies to the feeder just inside the entrance, the catcher rushes to the open end and the hummingbird usually flies away upward and toward the back of the enclosure. Often the bird does not become entangled, and the catcher gently crowds it into the netting, where it is easily removed. When no one is watching the trap, most hummingbirds enter, feed, and depart, but a few get caught, thus close monitoring is necessary.

### 5.6.3. Concerns/cautions

When large numbers of hummingbirds are present, this trap often catches them more rapidly than they can be banded. If the trap monitor ceases to force birds into the netting and allows them to feed and leave the trap, the rate of capture drops markedly. Care should be taken with this trap to ensure that birds are not caught more quickly than they can be processed creating a backlog of birds. If this trap is not watched constantly, it should be checked every 10-15 minutes (more often if it is windy, very hot, or cold).

This trap is not as effective when it is windy as the movement of the netting deters many hummingbirds from entering the trap. It is also time consuming to set up and is often more suitable in a permanent location where the poles can be left in place and the netting taken off when not in use.

While prompt removal is usually simple, occasionally hummingbirds become severely tangled. Some birds may have been caught in the outside netting when trying to get to the feeders not at the open end. The trap may also catch squirrels and chipmunks, other nectar-feeding birds, and birds flying through the area where the trap is set up, therefore this trap should not be used unless the bander has a mist net endorsement on their permit and experience extracting other species from mist nets.

Figure 14. Mist net trap ("Russell" Trap) (photo: Lee Rogers).

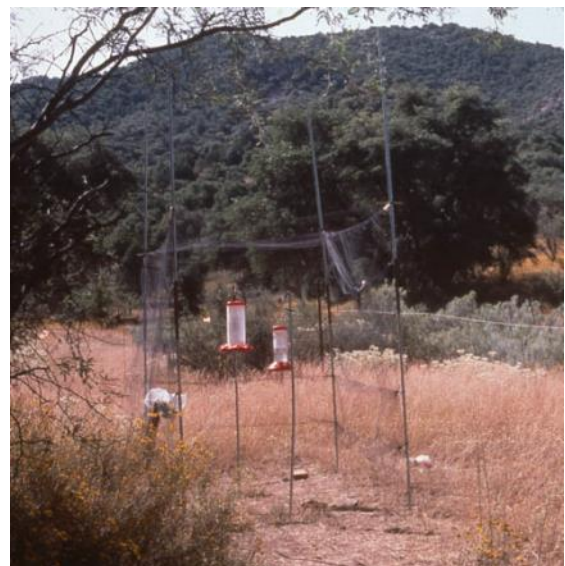
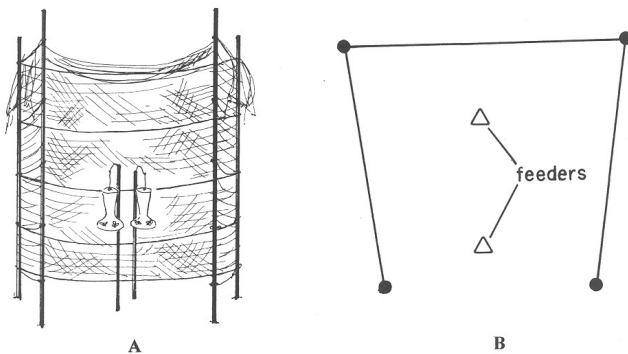

## 5.7. Modified Mist Net Trap

### 5.7.1. Design

This trap is similar to the previous net trap, but the top netting drops approximately 1 ft/30 cm over the entry side. A feeder is placed on a short pole about 0.6 m above the ground, just inside the entrance and below the leading edge of the roof net. At least two other feeders are placed farther back and higher up near the side walls. This design allows hummingbirds to be caught without a monitor to herd every bird into the trap. See guidelines for the construction of this trap ([Appendix C.7](#)). Another modification includes draping the poles with 3/8" (about 9.5 mm) netting (not mist nets) on all sides except the entry door, which is only half hung. If the "box" is made big and tall enough, with the feeders placed low, there is no need for trammel effects of a mist net - the hummingbirds remain inside, forgetting how to exit.

### 5.7.2. Use

Birds attracted to the feeder at the entrance usually fly to the back feeders on their own. Once there, they instinctively fly up, seeking an exit. Anyone who approaches the front causes the bird to fly to the rear, where it can be carefully caught. Some birds are caught in the netting when it is not directly monitored, so this trap should be checked at least every 10-15 minutes (or more frequently when during hot or cold weather). It is useful when few birds are present and the bander is working alone or without experienced assistants. When banding assistants are available, the Russell net trap is recommended.

### 5.7.3. Concerns, cautions

Same as Russell trap (see above).

Figure 15 – A modified walk-in Russell trap (photos: Sumita Prasad).



## 5.8. Mist Nets

### 5.8.1. Design

Instructions for the use of mist nets are provided in the Banders' Study Guide (<http://www.nabanding.net/wp-content/uploads/2012/04/STUDYGUIDE1.pdf>). In general, mist nets set in linear arrays are not effective when hummingbirds are the primary objective. Nets set in native habitats to sample the avifauna, as at MAPS (Monitoring Avian Productivity and Survivorship) and other constant-effort stations, will capture a few hummingbirds, but when they are the primary objective, baited traps (including traps using nets) are more effective.

### 5.8.2. Use

Nets may be useful where feeders are not used, in situations with high numbers of birds at concentrations of food, such as at flowering trees or in meadows with many hummingbird-pollinated flowering plants. Migratory flight paths may occur locally at creeks, rivers, edges of large bodies of water, trees at the edge of the Gulf of Mexico, bluffs, canyons, valleys, etc. In these situations, place one or more nets (24-mm mesh) perpendicular to flight paths where hummingbirds are seen moving predictably. Placing feeders strategically may attract birds to sites where they can more conveniently be captured. Nets set in lines are most effective when the air is still and temperatures moderate. Light wind makes the nets more visible, and stronger wind causes the

netting to become taut, increasing the chances of injury. Nets placed in shadows and against dark backgrounds are less visible and may be more productive.

Pre-baiting with several to dozens of hummingbird feeders frequently attracts many birds during migration and at breeding and wintering sites. The more feeders, the more rapidly hummingbirds find them. Feeders should be placed in clusters within a few meters of each other. They can be hung from vegetation, or placed on stiff hooks inserted in short (<1.5 m) sections of EMT conduit driven into the ground. As hummingbirds return to the exact location of a previous food source, feeders should be positioned near later trapping locations. When birds become familiar with an array of feeders, some may be removed to entice birds to the area where nets or traps are set.

Cage and net traps are most effective in the exact location where the feeder(s) are used in prebaiting. It is also useful to keep feeders at non-disturbed locations during the trapping operation as alternative feeding sites. When only one or two feeders are used to attract hummingbirds and they are defended by aggressive birds, increase the number of feeders. When large numbers of birds are present, individual birds are usually unable to exclude others from the feeders.

### **5.8.3. Concerns, cautions**

Hummingbirds (and other birds) should not be removed from mist nets by anyone untrained. The risk of injury or death is too high. Nets should be checked every 30 minutes at a minimum. If conditions are extreme, i.e., windy, in sun, or temperatures <20°C (68°F) or >32°C (90°F), check nets every 10-15 minutes or close them if capturing a bird could harm it. Hummingbirds can fly through or become tangled more easily in regular passerine nets. When hummingbirds are being targeted with mist nets, 24 mm mesh is the best choice.

## **5.9 Hummingbird Feeders for Trapping**

Feeders are used for many trapping operations. The following should be considered:

- ease of transportation when moving between banding sites;
- fit of feeder within your trap;
- ease of cleaning;
- dangers to hummingbirds (no small gaps that could catch a hummingbird's leg);
- cost;
- durability, particularly where packing for travel (plastic versus glass).

### **Sugar Water Ratio**

Flowers that attract hummingbirds typically have 20-25 % sugars, but sometimes can be greater than 30%. One cup sugar in 3 cups water is ~28% sucrose and a ratio of 1:4 is ~21%. We recommend not straying too far from this ratio, whether more concentrated or more dilute. When hummingbirds drink sugar water that is too concentrated it has the potential to create an osmotic gradient that can damage the gut, increase the chance for a *Candida* infection, and also create preening issues. If too dilute, the birds may potentially excrete more water and electrolytes. If hummingbirds are eating enough insects, then they will balance their electrolyte load, but in the winter if they drink too dilute of a solution, and potentially have fewer insects to eat, dehydration could be an issue. Dietary water important for cooling and thermoregulation in all seasons, therefore we recommend a ratio of 4 parts water to 1 part white sugar. In the winter a 3:1 ratio may be appropriate, but we do not recommend any concentration higher than this, especially if there is not freely available water to drink (i.e. an unfrozen fountain, pond, etc.). White, refined sugar must be used. Do not use brown sugar, honey, raw sugar, or molasses since these iron sources can be very problematic for hummingbirds (iron storage disease). Do not use red dye – it is unnecessary and potentially harmful to their health. Unused solution may be stored in the refrigerator for up to 2 weeks.

### **Cleaning feeders**

Clean feeders are crucial if hummingbirds are to remain healthy. Once the solution in a feeder becomes cloudy, it should be replaced, the feeder cleaned, and the feeder refilled with fresh solution. Feeders should be occasionally soaked in a solution of one part bleach to ten parts water, full-strength white vinegar or full strength (3%) hydrogen peroxide; use a bottle brush or pipe cleaner to remove any mold or grime. Disinfected feeders should be thoroughly rinsed and allowed to dry if possible. Feeders are best cleaned at night so as to not disrupt the feeding of the hummingbirds; alternatively, extra feeders can be kept on hand to use while the dirty feeders are cleaned.

## 6. HANDLING, HOLDS, AND RESTRAINTS

For assessment of a hummingbird's condition prior to, and during the banding process, see [Section 7](#) for details on stress, injuries, disease, and euthanasia.

### 6.1 Handling of Hummingbirds

Hummingbirds are handled and restrained during the banding process for the following reasons:

- To remove the bird from the trap or net
- To transport the bird from the capture location to the banding table
- To apply the band
- To take measurements
- To assess the bird's health and condition
- To feed the bird before release
- To release the bird after processing
- To transport a sick or injured bird to a qualified rehabilitation facility

Hummingbird banders use a variety of methods to hold and restrain birds. The particular method used and preferred by each bander is largely a result of training and experience. Furthermore, the size and conformation of each bander's hand will influence which holds work best for that person. All of the methods presented herein may be used safely with proper training and attention to detail. By the same token, all of the methods have drawbacks that can be harmful to birds if the bander is not vigilant. We have attempted herein to identify the positives and negatives of each method. General considerations that apply to ALL methods of handling and restraint are listed here:

- Always prioritize hummingbird comfort and safety over data collection and public education.
- Always monitor the bird for signs of distress and for health issues during the entire banding process.
- Always have clean hands for handling hummingbirds. Wash and dry hands regularly during the banding session to reduce the chance of becoming a vector for disease.
- Never use lotions, insect repellent or sunblock on hands that will handle hummingbirds. The residues from these products can transfer to the bird's feathers and may be harmful to feather condition. The bird may also ingest potentially toxic residues during grooming.
- Never try to grab a hummingbird that attempts to struggle free. Hastily snatching at a bird may result in injury.
- Never hold a hummingbird by the bill alone. The bill is a delicate structure, and if a bird is held only by its bill, the bird's weight could cause stress. Rapid wing beating could place severe torque on a structure unable to accommodate it.
- Never hold a hummingbird by the legs or feet alone. The feet and lower legs are delicate and vulnerable to injury. Do not hold a hummingbird in the "photographers grip" used by passerine banders, even for photographs.
- Never hold a hummingbird by the wings alone or by pinching the wings together over the back. This can result in severe injury.
- Always use light pressure to restrain the bird, paying particular attention to the chest, thorax, and abdomen. Never put pressure on the chest, thorax or abdomen as it may restrict the bird's breathing.
- Always ensure that birds being held for processing are kept in a quiet place, away from wind and direct sun.
- Never hold birds for longer than 30 minutes, with the exception of birds that will be transported to a qualified rehabilitation facility. The handling and transport of injured birds is discussed in Chapter 6.

### 6.2 Holds

#### 6.2.1 Fingertip Hold

The Fingertip Hold (Figure 16) is a safe and secure means of transferring a hummingbird from a net or trap to a holding bag. Some banders' use it when measuring. This hold is often used when hand feeding a hummingbird. When used properly, the bander has a clear view of the bird's eyes and bill, and therefore is able to monitor for signs of distress. The bird must be held with firm, but gentle pressure and never squeezed. The thumb and second finger should be placed on either side of the bird on top of the wings, and the first finger on the back. The fingers on either side of the bird gently control the bird's wings, preventing flapping. This hold allows the bird to remain in a natural, upright position (i.e., not in an unnatural "belly up" position).

**Cautions** - Great care must be taken to **never** exert pressure on the chest, thorax or abdomen. To minimize the tendency to place the third and fourth fingers on the bird, it is suggested that they be folded into the palm of the hand.

Figure 16. The fingertip hold. Note that the fingers are on either side of the bird and on the back only - there are no fingers on the chest or abdomen (photo: Anthony Hill).



### 6.2.2 Reverse Fingertip Hold

The Reverse Fingertip Hold (Figure 17) is an alternative for extracting a hummingbird from a net, trap, or holding bag and provides access to all parts for banding and measurements. In contrast to the standard fingertip hold, the bird's head faces toward the palm. The thumb and second finger are placed on either side of the bird and the first finger is lightly placed on the back. This hold allows the bander access to the underparts to check for bands, apply bands, measure tail length, check for fat, molt, breeding condition, and parasites; slight rotation of the bird's body allows measurement of the culmen and wing chord. This hold is also useful for transferring the bird from the bander to another team member for feeding.

#### **Cautions:**

- Care must be taken that the bill is not pushed against the palm or other fingers, or bumped.
- Great care must be taken to **never** exert pressure on the chest, thorax or abdomen.
- Because the eyes and bill are not fully visible, care must be taken to regularly check for signs of distress.

Figure 17. The reverse fingertip hold (photo: Anthony Hill)



### 6.2.3 Hummingbird Banders' Hold

The Hummingbird Banders' Hold (Figures 18 and 19) can be used in handling hummingbirds. **This is very different from the banders' grip used for passerines.** The body of the bird is carefully grasped in the palm of the hand with the ventral side facing out, dorsal side against the palm. The head should extend between the first and second fingers with the neck between the proximal knuckles and the fingers gently closed around the body. The second finger is bent to

create sufficient space so that there is no pressure on the hummingbird's neck, thorax, or trachea – **this is key**. When the bird is correctly positioned, wing flapping will be minimized because the curved second finger provides a gentle enclosure on either side of the bird's shoulders. This hold permits all necessary measurements while maintaining a secure hold. By holding the first and second fingers in a firm but relaxed grip, the bird will not be endangered, nor will it escape. The third and fourth fingers may be curled loosely around the body to help control the wings. The bird should always be held in a normal "upright" position with its head above the rest of the body so that regurgitation of fluid is minimized.

Figure 18. The hummingbird bander's hold - lateral view (A) and ventral view (B).

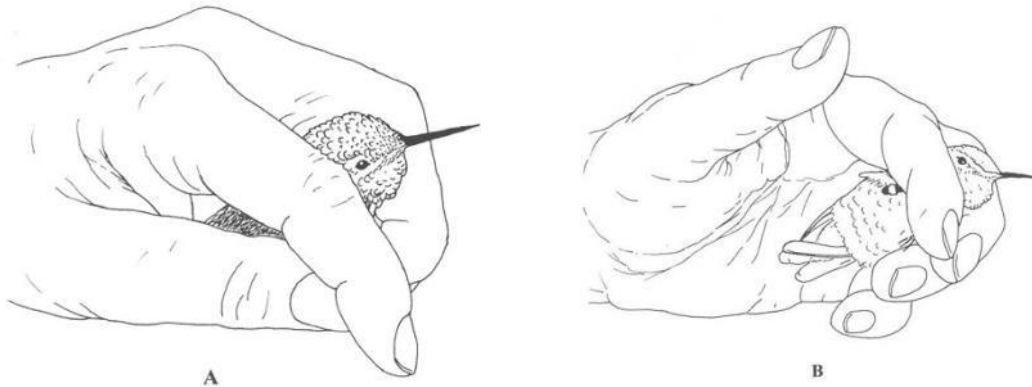
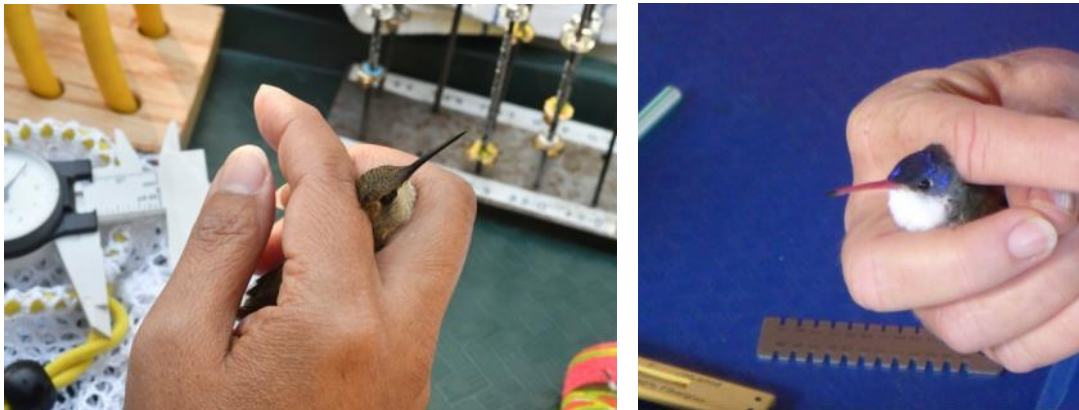

Figure 19. Hummingbird banders' hold showing curved second finger (photos: Anthony Hill and Lee Rogers).



#### Cautions:

- The bander will usually hold the bird in his or her non-dominant hand. Since the non-dominant hand may lack dexterity and the bend in the second finger is not a natural position, to master this hold requires training and practice. Furthermore, some modifications of the hold are required depending upon each individual's anatomy. Bander's with large hands may find this hummingbird hold challenging.
- Care must be taken to avoid hyperextension of the neck, pressure on the trachea and flapping of the wings.
- Care must be taken to ensure that the bird is positioned with the head extending beyond the fingers, and the eyes are not in contact with the fingers.
- Because hummingbirds are extremely small and have short, fragile necks, banders with larger hands should use extreme caution with this hold, as larger fingers can inadvertently cause injury.
- Passerine banders who are familiar with the passerine bander's grip will note some similarities with the hummingbird bander's hold. **HOWEVER**, key differences are the bend in the second finger and the loose curl of the third and fourth fingers which prevent pressure on the hummingbird's neck and trachea. Extreme caution is required, because fingers trained in the passerine bander's grip (which is dangerous for hummingbirds) must be retrained to successfully master the hummingbird hold.



## 6.3 RESTRAINTS

There are many different styles of hummingbird restraints, each with their own strengths and weaknesses. The most frequently used are discussed further, but all restraints have the same goals: safe handling and efficient processing.

- All restraints should be washed in detergent and thoroughly rinsed and dried after each day's use.
- Any restraint used to hold a bird that shows signs of infection should be set aside and not reused until washed with dilute bleach.
- Restraints should be checked regularly for holes, wear, fraying fibers

### 6.3.1 Holding Bags

Holding bags are used to contain the bird between capture and processing. Only one hummingbird should be placed in each holding bag. The trapper places the bird in the bag and takes care that the closure is properly secured to prevent escape. The bird in the bag is then carried from the trapping site to the banding table by the trapper, and the bag is usually hung by the drawstring from a rack. The rack should be located in a quiet place that allows each bag to hang freely without contacting other objects. The rack should be protected from wind and direct sun, and within reach of the banding table. Birds should not be held in bags for longer than 30 minutes. If a bird is going to be held in a bag for any length of time, especially if it was captured in a mist net, it may be appropriate to feed it first.

When removing a bird from a holding bag, the bag should be carefully opened, a free hand inserted carefully into the bag and the top of the bag tightened around the wrist until the bird is safely secured. Most right-handed people measure with their right hand and hold the bird with their left, and vice versa. It is best to remove the bird from the bag with the hand that will be used to hold the bird for processing. This avoids unnecessary transfer between hands, which can increase the likelihood of flapping and escape. Before removing a hummingbird from a holding bag, a person must be familiar with the various holds that permit safe handling.

Holding bags may be made specifically to hold hummingbirds or bought from a variety of sources. Several types of bags are available. In all cases, the bag should be made of a soft material that will not abrade the bird's feathers. A secure drawstring closure is required to prevent escape. For all materials, the seams should be constructed to prevent fraying fibers that might entangle the bird's feet, wings, bill, or tongue. Some options to prevent fraying are French seams, flat-felled seams, serged (or overlocked) seams, and seams bound with bias tape. Using the bags "inside-out", with the raw seam on the outside and the finished seam on the inside, is also an option. Bags of different types are described below.

#### A. Coarse-mesh bags

Many banders favor bags with a large mesh size (seine material with a mesh of 3.5 x 6 mm is ideal) that permits observation through the bag to monitor the bird's condition while it is waiting to be processed. A possible drawback is damage to wing and tail feathers if the bird is highly active in the bag. Careful monitoring is essential. An example of a holding bag made from seine material is shown in Figure 20. Directions for making drawstring bags from netting-type material are provided in [Appendix C.7](#).

#### B. Fine mesh bags

Some banders use military or camper mosquito head nets with draw strings, which allow birds freedom of movement between capture and processing. The fine mesh allows the bander to view the bird while it is in the bag, and monitor the bird's condition. The bird must be removed from the bag to apply the band and to perform measurements.

#### C. Muslin bags

Light-weight, cotton muslin bags may be used to hold birds after the bird has been removed from the trap or mist net. These bags are favored by some banders because the bird cannot see through the bag, thus creating an environment that is less stressful for the bird while it is awaiting processing. A disadvantage of muslin bags is that the bander cannot monitor the bird's condition through the bag. The bird must be removed from the bag to apply the band, perform measurements, and monitor the bird's condition.

Figure 20. A holding bag made from seine material.

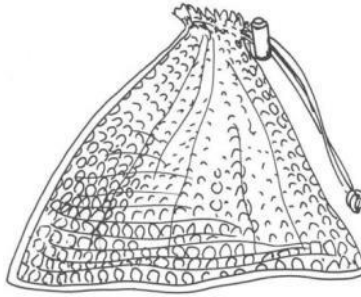

### 6.3.2 Stocking Toe Hammock

Some banders use the cut-off toe of a soft stocking or a nylon footlet to help restrain the hummingbird while the band is being applied and the measurements are taken. The stocking toe hammock requires the toe of a soft stocking, as in Figure 21. The hummingbird is laid in the stocking toe, with the head nestled at one end of the stocking toe (Figure 22). **The bill protrudes from the stocking toe opening and at least one eye is clearly visible.** The surface quality of the material has enough friction to keep the hummingbird in place while making measurements and placing a band on the bird's tarsus. The bander may gently hold the sides of the stocking toe against the bird's flanks with the wings folded to prevent flapping. The bird rests comfortably in the hammock, and the bird is easily monitored for signs of distress. A hummingbird is easily restrained in the stocking toe for typical measurements, and by using a small clip the bander may wrap the material over the hummingbird and weigh the bird on a digital scale. The bird is easily transferred to the fingertip hold or the reverse fingertip hold for further processing.

The stocking toe hammock should be made from a soft fabric with a little stretch. Knitted cotton stockings are a good choice because they are soft, slightly stretchy, and have enough body to form the hammock. The toe of the stocking should be cut off 1 to 2 inches (2.5 – 5.0 cm) above the toe seam. The raw edges formed by the cut may curl outward slightly, away from the bird. The light-weight nylon footlets that women wear inside dress shoes are the perfect size and already have finished edges. The material should allow air movement (freely breathable) and birds should not be held too long especially when it is hot (air movement is probably not favorable)

Figure 21. The stocking toe hammock (large numbers are centimeters).



Figure 22. The stocking toe hammock being used during a wing chord measurement.



### 6.3.3 Stocking Toe Cocoon

Some banders use the cut-off toe of a thin nylon stocking to help restrain the hummingbird while the band is being applied and the measurements are taken. The stocking toe cocoon requires the toe of a light weight, stretchy nylon stocking, cut off to a length of about 5 inches (12.5 cm). **The hummingbird is laid dorsal side down in the stocking toe, with the body, head, and bill completely enclosed within the stocking toe** (Figure 23). The stocking must be very thin, soft and stretchy so that the bird is never constrained in an unnatural position. The stretchiness of the stocking toe against the bird's body, with the wings folded, prevents flapping. The bird rests comfortably in the stocking toe. The bander can easily manipulate the stretchy opening to expose different parts of the body, as needed for applying the band or taking measurements. The bander must check the bird's condition regularly for signs of distress. The stocking toe opening can be folded back, away from the bird, to transfer the bird to the fingertip hold, the reverse fingertip hold, or the hummingbird banders hold for further measurements.

The stocking toe cocoon should be made from a very light and stretchy nylon stocking. The color should be light to permit easy viewing. Women's light weight pantyhose are a good choice because they are soft, very stretchy, and come in light colors. The toe of the stocking should be cut off about 5 inches (12.5 cm) above the toe seam. The raw edges formed by the cut may curl outward slightly, away from the bird.

Figure 23. The stocking toe cocoon (photo: Lanny Chambers).



### 6.3.4 Casting Jacket

Casting jackets are fabric restraints used to assist the bander in controlling the hummingbird while applying the band and taking measurements. The design of the casting jacket has evolved over time. Older designs should **NEVER** be used because of the chance that the hummingbird will fly away with the jacket still attached over its neck (the old "poncho" design). The design has been modified to improve both function and hummingbird safety. The current design, described herein, is safe to use with proper training.

The pattern for a casting jacket is shown in Figure 24. This pattern is appropriate for small and medium-sized hummingbirds, such as Rufous, Calliope, Black-chinned, Anna's, and Broad-tailed hummingbirds. An adjustment to the pattern is necessary for larger hummingbirds to ensure a good fit.

Figure 24. Pattern for a casting jacket for small hummingbirds (length ~3.5 inches (~9 cm), widest width ~3.5 inches at bottom, and ~2 inches (~5 cm) at top) (Lisa Roig and Ann Nightingale).

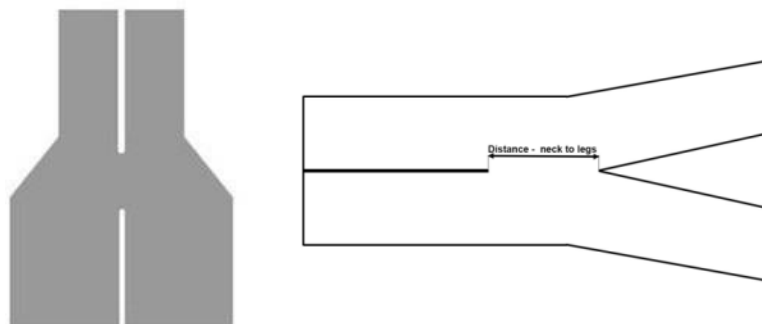

The casting jacket is first laid flat on the table. Using the fingertip hold, the hummingbird is transferred from the holding bag and placed with its breast in the center of the casting jacket, with its head facing the top flaps. Keeping the bird under control with the fingertip hold, the bander uses her other hand to bring the top flaps of the casting jacket up around the bird's neck. The bander then pinches these flaps behind the bird's back (Figure 25).

Figure 25. Positioning the top flaps of the casting jacket around the neck (photo: Ann Nightingale).



The birds' wings should now be comfortably constrained against its body by means of the top flaps. The bander now pulls the bottom flaps of the jacket up to meet the top flaps behind the bird's back. Next, the jacket is secured by means of a straight pin or an alligator clip (Figure 26). If using the straight pin, always position the pin so that the sharp point is facing away from the bird's head. Training and experience are required to use the pin and clips properly, so that the jacket is secure but not excessively tight. If the jacket is too tight, birds will gape or open and close their bills excessively, and suffocate. This restraint method is safe and effective, but does require more training than other methods.

Figure 26. Securing the casting jacket with a straight pin or alligator clip (photos: Ann Nightingale).



If the jacket is positioned correctly, the birds wings will be comfortably restrained against its body, the head will be exposed, and the feet will be exposed so that the band can be applied (Figure 27). When used properly, the bird can easily be monitored for stress while the band is being applied. Both of the bander's hands are free to operate the banding tools. Some measurements, such as the exposed culmen and traits involving the tail, can be made while the bird is restrained. Once the closure is removed, the jacket slips easily off of the bird during transfer to the fingertip hold or the hummingbird banders hold.

Figure 27. Correctly positioned casting jacket with legs exposed for banding.

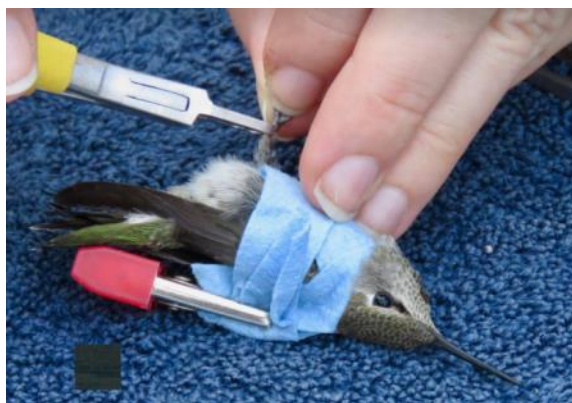

A **reusable** casting jacket can be made from soft fabric, such as cotton flannel, that is washable. Care must be taken to minimize fraying of the fabric so that small fibers do not entangle the bird's feet. Fraying can be minimized by cutting the pattern on the bias of the fabric, or by binding the raw edges using sewing techniques. A **single-use** casting jacket can be made from non-woven shop cloth. Enough single-use casting jackets must be made in advance of the banding session for the anticipated number of birds to be processed. Single-use jackets reduce the chance of transferring pests or disease between birds (the jacket is thrown away after one use), but they create more waste than the reusable version (which is washed between uses).

## 7. STRESS, INJURIES, DISEASE, and EUTHANASIA

Most hummingbirds cope well with capture and restraint, but some individuals may not. It cannot be assumed that the bird is in excellent health at the time of capture, especially during migration. The bird must be monitored for signs of compromise during handling. Occasionally the inadvertent strain from handling alone may cause a bird to go into shock. Signs of compromise may include: eyes closed, feathers fluffed as if cold, body limp and tongue protruding, or labored breathing, especially a 'jerky' spasmodic motion with each breath (which can also be an indication of aspiration).

If a bird does not fly away after being held on an open palm for a minute or two, and has not fed, it should be provided with supportive care, as noted below. If it has fed, but does not fly, it should also be provided with supportive care until it is ready to fly. If cold or wet weather develops, care must be taken to ensure the bird does not become chilled or get wet while it rests. Hummingbirds under high stress, especially early in the morning, may drop back into torpor and appear lifeless, sometimes for more than an hour. Banders must be aware of this and be advised to place an apparently dead bird in a warm, monitored container until rigor mortis sets in (i.e. the head no longer flops when the bird is moved), confirming that the bird has, in fact, died).

### 7.1. Signs of Distress

Normally, hummingbirds should be alert and responsive prior to and during the process of being handled. However, for a number of reasons, a hummingbird might be compromised prior to or during handling thus careful attention and pre-emptive measures might be necessary. A compromised bird is one that might be unable to function optimally. A bird that is compromised may exhibit one or multiple of the following signs:

- Eyes blinking or closing signifies a compromised bird. This may be as simple as a loose contour feather in the eye, or it may indicate physiological or anatomic compromise secondary to handling, pain, hypoglycemia, hypothermia, disease and/or injury.
- Bill gaping, gagging motions: may result from being held too tightly, excessive pressure on the esophagus or trachea ("windpipe") or regurgitation and aspiration of fluid from the crop.
- Fluffing of crown feathers and or body feathers. If the bird is exhibiting this behavior, evaluate the status of the bird and reduce handling time.
- Processing a female with an egg should be conducted with great care and expedited to reduce processing and handling time

Some birds may require time to recover from a compromised condition. Every banding kit should have a portable field intensive care unit. This allows the bird to be placed in a dark warm environment and away from stimulation. The unit should have some kind of

warming system which will not pose a risk to burning the bird. Food availability should be determined based on the bird's physical condition. Check on the bird every 10-15 minutes to see if the bird is recovered and ready to be released.

A bird that is fearful might exhibit different signs from compromise and include the following:

- Release of contour body or tail feathers can be a defensive response to a stressful environment. This behavior should trigger the bander to pay special attention to the bird in hand and the bander should reduce handling time.
- A bird that is excessively vocal should be treated with care. The bander should evaluate the physical position of the bird, check wings first to ensure the bird is in a safe and comfortable position. If the bird continues excessive vocalization without human contact, then offering a SMALL amount of food may help.

## 7.2 Duration of Restraint

Factors to keep in mind that influence how long a bird should be restrained include stress level, time of day, the birds' sex, and the season. Reduce handling and restraint time as much as possible. Close your nets and traps if you're catching too many birds. Adding restraint stress to birds that are already experiencing high stress levels (time of day, nutrition etc.), can potentially be excessively stressful, with potential harm to the bird or to its breeding effort.

**Stress** – stress increases with restraint length. A British Columbia study (Hiebert et al. 2000) put hummingbirds in a cloth restraint bag and collected cloacal fluid every 30 minutes before, during and after the restraint. Birds were fed every 10 minutes. Stress hormone (cortisol on the Y axis) increased with restraint length (Figure 28).

Figure 28. Stress response with increased restraint time (from Sara H. Bursch).

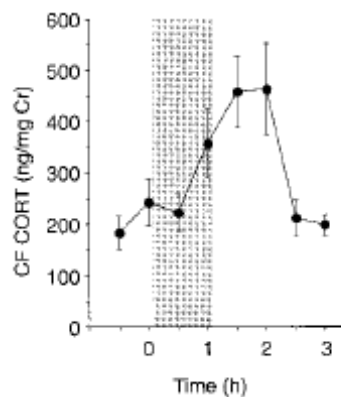

**Time of day** - birds feed at very high rates in early morning and late evening and their survival likely depends on it; so disrupting this pattern of feeding is likely to leave them with an energy shortfall. Please minimize the length of restraint, particularly around the time of first feed.

**Sex and season – whether a female is nesting should inform restraint time** - Females feed nestlings approximately every 10-15 min. This means that a female provisioning nestlings is providing warmth and food at regular short intervals. Prolonged restraint (>15 min) of nesting females could therefore impact nesting success. Please minimize the length of restraint to recognize the activities of nesting females.

## 7.3. Injuries and Disease

Hummingbirds can survive bill injuries without treatment depending on the severity of the injury. A minor scrape on the tarsus may be treated with a small amount of Preparation H® (active ingredient is a vasoconstrictor) before release. A totally incapacitated bird requires sustained treatment, and the bird should be transferred to a licensed rehabilitator. Banders should establish a relationship with avian rehabilitators who are qualified to treat hummingbirds. See Appendix E for additional information. Special considerations for hummingbirds with “pox” like lesions should be taken into account before banding the bird. Proliferative skin lesions can be present on legs and placement of a band could severely compromise the limb. Even if lesions are not yet present on the leg, avoiding band placement should be considered in order to prioritize the bird's welfare.

### 7.3.1. Zoonotic Diseases

A survey of diseases found in hummingbirds (Magna et al., 2019) has shown that hummingbirds can be infected with microbes that could be infectious to humans. Therefore, precautions should always be taken to minimize the potential for zoonotic diseases

(diseases transferred from animals to humans and vice versa) including vigilant hygiene practices (washing hands, minimizing transfer of urine/fecal material), sanitizing equipment and work areas, and not having beverages or food in the immediate work area.

### **7.3.2 Sanitary procedures for cleaning restraints and tools**

Animal handlers such as veterinarians and rehabilitation practitioners take precautions not to be vectors of disease between the animals handled. It is advised to clean all tools with either 70% isopropyl alcohol (evaporates without residue) or sodium hypochlorite wipes and then rinse thoroughly with water afterward. Any cloth materials coming in contact with diseased birds should be set aside and washed with sodium hypochlorite before being used again. Humans can use an alcohol-based hand gel after working with a diseased bird allowing for adequate contact time (2-3 minutes) and then rinsing with water afterwards to avoid residue transfer to the birds' feathers; these techniques work well in concert with the single use wraps. These sanitary protocols could help reduce the opportunity for vectoring disease and are not time consuming when it is a habit and it reduces the opportunity to be a vector for disease.

## **7.4 Treatment/Supportive Care**

If a bird shows any signs of compromise, the banding process should be suspended immediately and sugar water offered, but not forced. If the bird does not drink and improve, then the bird placed in a container where it can recuperate. A compromised bird should be placed in a container and supported so that the head is upright. The container and bird should be placed in a warm dry place away from noise, wind or other disturbance. The bird's condition should be checked every 5-15 minutes and sugar water may be offered once the bird is able to hold its head upright and is alert enough to feed.

Hummingbirds typically become compromised when they are low on energy (hypoglycemic). This most often occurs on cold mornings—but it can happen under any conditions, especially when capturing hummingbirds with mist nets rather than feeders (feeder-caught birds nearly always have a meal at the feeder right at the moment of capture, whereas a mist-netted bird may not have fed recently). In most cases, after nourishment and warming, the bird will soon ready to be released. It is occasionally recommended that a person wearing a loose jacket can try to hold the bird in its carrying bag inside the jacket; this will help keep the bird warm until it can be placed in a more suitable warm place. Placement of the bird inside a jacket is not as ideal as placing the bird in a warmed, well-ventilated container as placement in a jacket carries the risk of poor ventilation and increased carbon dioxide exposure. If the bird appears to be in shock or lifeless when brought to the banding table, it may be placed under a lamp or on a heating pad where the temperature is no more than 100°F (38°C). If there is no electricity, a hand warmer pack (e.g. <http://www.warmers.com/> or <https://hotsnapz.com/>) can be used. As soon as the bird becomes alert, it should be offered sugar water. A “mini hospital” chamber can be made from a large round plastic container where a large circle can be cut out of the lid and replaced with a fine mesh to allow for adequate ventilation within the chamber. A hand warmer pack can be placed in the container but the bird should never be placed directly on the warming pack and the warming pack should be covered with a thin sock or some material to ensure that the bird cannot come in direct contact with it.

When energy reserves are near depletion, or in weather-extreme conditions, hummingbirds may become torpid, with associated body temperature drop, accompanied by slowed respiration and metabolism. Oral fluids must never be given to an unconscious bird, or to one that cannot hold its head upright. Placing the bird in a warm and dry location is optimal. Banders should always have some kind of 'mini hospital' (see above) container available so that patient restraint is minimized and to ensure that a bird can be warmed up quickly and efficiently.

As previously mentioned, an extremely compromised bird should have minimal oral fluid intake because the bird could aspirate the fluid into its respiratory tract. Small amounts of sugar water should be offered at frequent intervals. When a bird appears to be injured, it must be remembered that excessive handling and restraint could compromise the bird even further. For short-term care, a bird should be kept in a warm, dark and quiet place. If long term-care is required, referral to a licensed rehabilitator may be necessary. It is recommended that banders' establish contact with a suitable rehabilitation facility or appropriately qualified veterinary practice *before* starting banding operations. Because that is not always possible, however, here are suggestions for care that may be helpful with some of the more common injuries.

Occasionally a bird cannot fly and will have difficulty perching; its entire body may move in a “panting” motion. Sugar water should be offered carefully, in very small amounts in order to avoid aspiration. The bird should then be placed in a small, warm box with material such as a paper towel or soft cloth in the bottom for footing. Air holes are essential; a heating pad (or hand warmer pack; see above) may be placed under the box for extra warmth if air temperature is <70°F (21°C). Sugar water should be offered, but not force-fed, every 10 minutes. NOTE: some banders' keep a supply of Pedialyte® pediatric electrolyte solution on hand to offer birds that appear compromised. Suitability of this product for hummingbirds has not been formally evaluated.

Infirmary Cages: Hummingbird banders or their sub-permittees are occasionally contacted by members of the public with reports of injured hummingbirds. In very rare cases a hummingbird may be injured in the course of capture and banding. In all of these

situations the master permittee is authorized to keep the hummingbird for 24 hours for care and observation. After 24 hours if the hummingbird is not capable of surviving on its own, it must be delivered to a licensed rehabilitator. Rehabilitators specializing in hummingbirds or other small birds may be contacted through state or province wildlife offices. During the period that the hummingbird is under the control of the permittee, a suitable cage or box that can safely hold the hummingbird for observation should have a perch and easily accessible hummingbird feeder.

Cage traps constructed of hardware cloth or netting (refer to the chapter on traps) may be easily adapted to provide a safe resting location for an injured hummingbird. The trap design can be scaled down to a smaller size if no feeder trap is available to provide temporary holding structure for the hummingbird. Alternatively, a cardboard box covered by netting can be useful, if perches and hummingbird food (20% sucrose solution or Nektar-plus) are available. During the short period of time that the hummingbird is under the control of the permittee, the floor of the cage or box needs to be kept clean and dry by periodically changing paper towels on the cage or box floor. The cage or box needs to be located in a quiet, warm, shaded area so that the injured hummingbird may rest. If it is necessary to feed the hummingbird, use extreme caution to avoid overfeeding or it may aspirate the nectar (see [Section 8.10](#)).

### **7.5. Death of a Bird**

The death of a bird is likely to leave the banding team shaken and with diminished confidence. As soon as possible, the person in charge should convene the team to discuss what happened and what procedural changes might be made to prevent reoccurrence. It is also important to acknowledge the emotions team members are feeling. If a bird dies during a banding demonstration, the team leader must be prepared to explain to the audience what happened and to deal with their reactions. It should be explained that accidents rarely happen and that the casualty will be salvaged and used for teaching and research purposes in an institutional collection. If the preservation and salvage process can be started at the demonstration site and visitors are told how the dead bird will be used, such discussion may allay some of the visitors' concerns. Banders' should have a plan in place for specimen disposition and be prepared to announce where it will be permanently deposited. The appropriate state or provincial wildlife agency should be contacted for information on bird repositories. A deceased bird should be deposited in a legal collection and reported, if required, as a salvaged specimen. Every effort should be made to salvage dead birds as they have great value in scientific collections.

If the bird expired after it was banded but before it flew away, the band may be removed with care and used on a new bird. The data may be saved in your records, identified as an unbanded but salvaged bird. If the bird dies before banding, the incident should be described in the daily journal (see [Section 9](#): Data Management).

An expired hummingbird that will eventually become a study skin should be placed on its back with its feathers smoothed in a normal manner. If available, a small piece of cotton or paper towel should be placed in its mouth, to absorb sugar water from the crop that can damage the specimen. The wings should be folded to the sides and the bill extended. The bird should then be rolled carefully in a piece of paper to form a stiff cylinder. The sides of the cylinder should be closed with tape and both ends folded over and taped closed with care taken to avoid damaging the bill or tail. The tube should be placed in a zipper-closure plastic bag with all available data (species, age, sex, date, precise location and name of person who salvaged the bird). Data should preferably be written with a soft pencil (especially if the data sheet will be placed inside the bag with the bird) or permanent marker, so that it is not obliterated by moisture, as a specimen without minimal information of date and locality is almost useless. The source of the specimen as a banding casualty should be included. The specimen should be placed in a freezer as soon as possible; an ice chest will serve temporarily. The best study skins are prepared from specimens in good condition.

If it is not possible to freeze the bird promptly, it may be preserved by an alternative means. The preparation of a study specimen or "bird skin" is the best solution, but this involves removing the soft tissues from the body and stuffing the body cavity with cotton, a specialized skill beyond the experience of most banders. Hummingbird study skins may be prepared by dehydration, but this is less desirable because the fat remains, eventually penetrating the skin and permeating the feathers. Dehydration is preferable to losing the specimen. Because they are so small, hummingbirds can be carefully pinned out like a large insect and dried at the lowest temperature (less than 300°F; 149°C) in a laboratory temperature unit/oven. To facilitate later examination of the rectrices, they should be spread before drying. One wing may be carefully removed and dried in a spread position - this facilitates checking for wing molt and wear. A 4-g bird takes about 4 h to dry and when dry it should be rigid, feel solid, and have no odor.

A federal and state permit for possession of a specimen collection may be required to maintain a collection of birds or their parts. Contact the appropriate authority of you wish to maintain a collection. For teaching purposes, study skins may sometimes be borrowed from an organization with the required permits. Banders are encouraged to report all banding-related mortalities to the BBL or the BBO. BANDIT has a reporting protocol for these mortalities and banders should follow these reporting procedures.

### **7.6 Euthanizing a Bird**

On rare occasions, euthanizing a bird may be required in order to end pain and suffering. A licensed rehabilitator can help make the decision as to whether or not rehabilitation is possible. Euthanasia guidelines and approved methods have been detailed by the



American Veterinary Medical Association (<https://www.avma.org/KB/Policies/Pages/Euthanasia-Guidelines.aspx>), the Ornithological Council for wild birds used in research ([https://www.aaalac.org/accreditation/RefResources/SS\\_WildBirds.pdf](https://www.aaalac.org/accreditation/RefResources/SS_WildBirds.pdf)) and the Canadian Council on Animal Care (<https://www.ccac.ca/Documents/Standards/Guidelines/Euthanasia.pdf>). Specific recommendations for humane and approved methods for euthanasia have been summarized in the review article by Tell et al. (in prep.). Only approved methods for euthanasia should be used if it is necessary to euthanize a bird in the field.

## 8. PROCESSING AND BANDING

### 8.1. Removing Hummingbirds from Nets and Traps

Individuals should not remove a bird from any net or trap until the proper techniques have been observed and learned. Birds must be handled with warm hands as cold fingers may chill a bird. With any bird handling it is always important to keep the hands as clean as possible and free of any foreign material, such as insect repellent or sunblock. After instruction, the trainee may, with supervision, remove birds. Hummingbirds generally should be removed from mist nets from the same side they entered. In a walk-in trap made of mist netting, this is usually obvious, as most birds are caught inside the trap. The first step is to ascertain which side of the net the bird entered. If tangled, gently spread the netting apart until you see an area of the bird with no net covering it. If this is not possible on one side of the net, try the other. The side with the clear ventral or side view is the side from which to remove the bird.

Most hummingbirds are only slightly entangled. If little netting envelops them, and apparently only the head and neck extend through the netting, gently grasp the bird in the Finger-tip Hold: thumb placed on one side of the bird's body, second (middle) finger on the other side of the body, and the forefinger on top of the bird. Ease the bird backward, toward you, while teasing the netting forward over the head. If netting restrains one wing, hold the bird with two or three fingers positioned on its back and the thumb positioned to one side of the bird. Ease the bird gently backwards, using the other hand to tease the net off the wing and head. After its head and wing are cleared, if the bird is still grasping the net with its feet, it will probably release it, but it is often necessary to pull the netting gently from the feet. The feet tend to take up slack in the net, slack that may be necessary for gentle removal of the bend of the wing (wrist) from net openings. It is essential to stabilize the leg when pulling netting from the feet. Although it is generally safer for the bird to remove it from the side of the net it entered, in larger mesh nets (30- and 36-mm), it is sometimes easier to extract it by gently pulling the bird forward through the net with one hand and using the other hand to free the netting. Each bird in a mist net will present a different set of circumstances and bird handlers should be prepared for this. Removing hummingbirds from other trap types is typically simpler, and can be done by very gently pinning the bird against the inside of the trap, and using your fingers and hand to create a very loose "cage" around the bird, or when appropriate using the fingertip hold to remove the bird. Care must be taken with soft-sided (mesh) traps as sometimes a bird's toes, claws, or bills can be hooked. Utmost care must be taken not to accidentally force their wings into an unnatural position.

### 8.2. Species' Identification

#### 8.2.1. Correct identification

A hummingbird bander should be sufficiently familiar with regional birds to determine species, age, and sex within a few seconds. In addition, a working knowledge of possibilities, preferably to the genus level, is desirable so that an unfamiliar bird can be readily identified. An unidentified bird should be fed after 10 minutes and released unbanded after 20 minutes have elapsed from the time of capture. Full data should be taken on such birds for possible future reference. Although BBL/BBO provide an alpha code UNHU and species number 4409 for "Unidentified Hummingbirds," this should be resorted to only when absolutely necessary. Justification for the use of this code will be required. An appropriate use for "UNHU" would be for a suspected hybrid and the justifying remarks should include the presumed hybrid combination. See below regarding photographic documentation of ambiguous or unusual birds. A thorough set of measurements must also be taken as part of the evaluation of a likely hybrid. Careful measurement of the tarsus with calipers or a tarsus gauge and reference to the Band Size table (Table 1), must guide the selection of the proper band size. This process must also be thoroughly documented. You should not place a band on a bird until you have determined the species. Some banders would suggest that hybrids, if carefully measured and photographed, might provide important information if banded.

#### 8.2.2. Sources of information

For identifying to species, knowing the age and sex of a bird while banding, and either creating keys or using existing ones is essential. The use of keys requires considerable familiarity with them and is gained only through long experience. Unfamiliarity with keys can prolong the banding process and is thus detrimental to the bird's welfare. Preliminary keys to females and juveniles of most hummingbird species of western North America may be found in [Appendix H](#). Peter Pyle's (1997) *Identification Guide to North American Birds, Part I* is an excellent single source for species identification and ageing and sexing of all North American hummingbirds. The bander must become familiar with it, particularly the first 40 pages, before attempting to use it with a bird in the hand. Some banders prepare a synopsis of the characters of the species in their area based on this guide. Useful keys to *Archilochus* and *Calypte* are found in Baltosser (1987); to *Archilochus colubris* in Leberman (1972); to *Stellula* in Baltosser (1994), and to *Selasphorus* in Stiles (1972). Williamson (2002) and Howell (2003) are primarily field guides, but the level of detail in these publications makes them very useful for banders.

Since hummingbird banders handle very few species compared to most banders, it is appropriate to recommend that they become familiar with the natural history of the species they are likely to encounter. The best source of information is the series *Birds of North America*. Separate species accounts have been published for the Allen's, Anna's, Black-chinned, Blue-throated, Broad-billed, Broad-tailed, Buff-bellied, Calliope, Costa's, Lucifer, Rivoli's (formerly Magnificent), Ruby-throated, Rufous and Violet-crowned hummingbirds. The current versions of these species accounts are available online via subscription (<http://bna.birds.cornell.edu/bna/>).

Specimen collections in museums or at universities and colleges are very useful. In these collections it is often possible to compare individuals of different species, ages, and sexes in detail not possible in the field. The wings of specimens are usually folded tightly to the sides, however, which makes individual feather comparison difficult, and manipulation of the wings or tail without damaging the specimen can be challenging. Most museums restrict access to their research collections; the curator of a particular collection should be contacted to determine institutional policy.

Other hummingbird banders are an excellent resource, often have had the same questions, and are willing to share their knowledge. The annual meetings of the Eastern Bird Banding Association (EBBA), Inland Bird Banding Association (IBBA), Ontario Bird Banding Association (OBBA), and Western Bird Banding Association (WBBA) may include useful papers or workshops. WBBA, IBBA and EBBA jointly publish the quarterly journal, the North American Bird Bander. Many hummingbird banders have been meeting every few years for workshops, demonstrations, papers, and discussions. These meetings usually include hands-on exercises in the field. The hummingbird banders group (HUMBAND) on the Internet should be followed for information (see [Appendix D](#)). At present, however, access to HUMBAND is restricted to licensed hummingbird banders (Master and sub-permittee) only.

### **8.3. Banding a Hummingbird**

#### **8.3.1. The banding locale**

Use of a shallow tray or terrycloth towel on the banding table is recommended when banding or shaping bands, to help contain any dropped bands. Banding hummingbirds calls for quiet, careful concentration. As a rule, the bander should be seated at a table with good lighting and all necessary tools. Outdoor sites should be selected for adequate lighting for the bander and appropriate protection from sun, wind, etc. for waiting birds. Be aware of the temperature (whether extreme heat or cold) and observe how the birds are reacting. Do not let birds sit in restraints while waiting to be banded in the direct sun – they can easily overheat. Likewise, for temperatures near freezing, observe the birds for distress and adjust accordingly. This may mean pausing banding operations until the temperature warms a few degrees.

Banding indoors is strongly discouraged because a bird occasionally escapes from even the most experienced hands. Escaped birds usually fly upward, often towards the brightest light source. Where light sources can be controlled, the easiest way to free a bird is to darken the room except for an exit door or open window. As an added incentive for the bird to exit, one or more feeders may be placed in the exit area. In extremely large buildings such as supermarkets or car dealerships, it is not possible to darken the area during the day, so a food source should be provided as an initial step. Another option may be to attempt mist-netting or trapping the bird, with feeders used as an attraction. Banding outdoors is the best solution.

#### **8.3.2. Restraining the bird**

Some banders prefer to band and process birds without the use of a restraint device. This may be accomplished by first preparing the band in the pliers before removing the bird from the holding bag. For other banders, safely and securely applying a hummingbird band often requires the use of both hands. This usually means restraining the bird by some means other than just holding it in the hand. Appropriate restraint reduces energy drain and risk of injury. There are several methods of safely restraining the bird, and each bander will have a personal preference based on how they were originally trained and which method works best for them. [Section 6](#) discusses restraints in more detail.

#### **8.3.3. Determining band size**

The Tarsus Gauge (see [Appendix B](#) and Figure 29) can be a useful tool in measuring tarsus variations and aid in individual size selection. The Tarsus Gauge is a tool that measures the widest axis of the oval tarsus to aid in determining the appropriate band size. The measurement is taken where the band is intended to rest, close to the toes. Calipers may also be used to measure tarsus size. Measure the widest axis. It is recommended that banders choose an appropriate band size for females to accommodate significant tarsal swelling during the breeding season.

Individual birds are measured by inserting the widest part of the tarsus into successive slots of the tarsus gauge until the sides of the tarsus just touch the edges of a slot. The edges of the **correct slot** should barely touch the skin on both sides creating the slightest friction. One slot smaller will obviously move the skin. One slot larger will be a bit loose. As noted above, the correct fit

will be felt as much as seen. Measurements should be taken just above the toes where the band is expected to rest and the resulting slot value used to calculate the band size.

Figure 29. Hummingbird Tarsus Gauge: A tool to measure the long (widest) axis of the tarsus and aid in determining band size (photos: Lee Rogers and Anthony Hill).

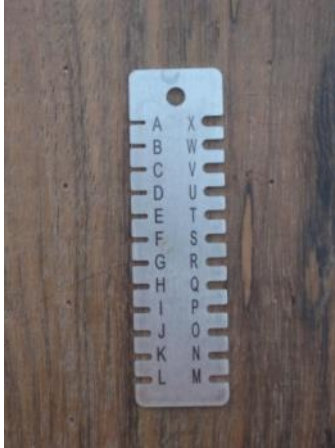

#### 8.3.4. Applying the band

At the banding table, essential tools must be within easy reach. To avoid possible double-banding, both feet and legs must be inspected before band application in case the band has slipped up above the intertarsal joint. The hummingbird is positioned, with or without a restraint, with its back down and legs up to be visible. When the feet are held tightly against the body, a large darning needle, #2 knitting needle or similar object may be used to locate the feet and check for bands. Often a gentle touch to the belly with the needle prompts the bird to extend its feet in search of a perch. Banding pliers (Figure 30) are available in sizes from 5.2mm to 7.9mm (see [Appendix B](#)) To achieve the best possible band closure and avoid potential bird injury the appropriate pliers should be used to apply each band size.

Figure 30. Banding pliers and other tools (photos: Anthony Hill and Lee Rogers).

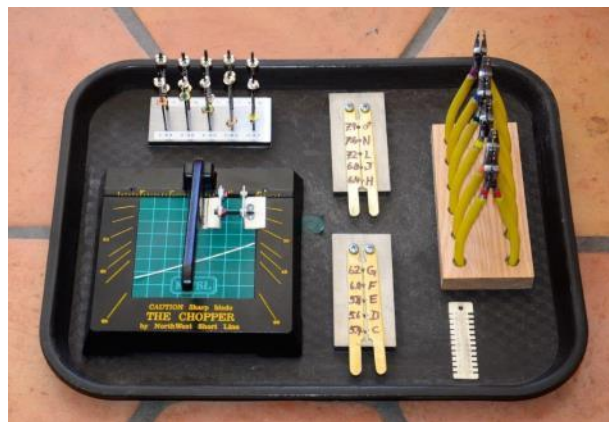

When the foot stocking or other cloth restraint is used, the bird is carefully wrapped so the leg to be banded is visible and positioned properly within the band so it is not pinched when closing the banding pliers. If mesh bags are used, the bag should be gently placed on the banding table with the hummingbird on its back. To avoid possible double-banding, both tarsi must be inspected before band application. Many birds clutch the mesh with their feet, thus making it easy to check for the presence of bands by gently pulling on the mesh. If the bird is holding the mesh, the toes may be gently grasped so that the foot may be extended through the mesh. If the feet are hidden, the mesh may be moved around over the breast and abdomen until a foot is found, can be grasped, and pulled through to the outside. The foot should be held between thumb and forefinger while the band is applied and closed in the usual manner. The hold on the foot should be maintained while the band is carefully inspected to verify that it is tightly closed and properly aligned, regardless of the banding method utilized. This step is very important as a misaligned

band on any bird can cause injury and, on a female, could become caught on nest lining. Most banders band all birds on the same leg, either left or right, but care must be taken to check both legs carefully for the presence of a band. As noted elsewhere, checking for bands should also be done at time of initial capture when feasible. During the banding process, both hands should always rest on the banding table to increase stability and minimize the chance of injury to the bird. Holding the banding pliers so that the hand is below the pliers will also reduce the effect of gravity and help stabilize the pliers. Bands should be applied with matching size pliers to ensure proper closure (Figure 31).

Figure 31. Pliers must match band size for correct closure (photo: Lee Rogers).



#### 8.3.5. Verifying fit of the band

When the band is closed and aligned, it should be checked to be sure the size is correct and it is not overlapped. It should spin freely, but not be so loose that it can slide down over the closed, extended toes. Judging the fit takes patience and practice, since leg size varies within each species and between sexes. It is critical to check to be sure that the closed band is not too snug (does not spin freely) nor too loose (able to slip over the toes when they are closed and extended). If necessary, the band should be removed (see Section 8.3.6 below) and replaced with a better-fitting band.

#### 8.3.6. Removing a band

Bands may be removed in several ways, all involving a restrained bird with the bander using both hands. The easiest method uses banding pliers or forceps to grasp the top and bottom of the band near the joint, and then the ends of the band are pried apart with a fingernail. If there is space between the tarsus and the band, the tips of very fine scissors (such as cuticle scissors), needle-nose forceps, or hemostat or band removal pliers may be placed inside the band to separate the tips and open the band. If the leg of a recaptured bird is swollen around the band, and this method does not work, the band may sometimes be cut with a toenail clipper. By snipping off enough of the end of the band, one cut lets the band fall away from the swollen leg. If substantial swelling or scabbing is present, however, it may be difficult to gain access to the band to pry or cut it. In the case of scabbing or dead tissue, Preparation H<sup>®</sup> may be applied to the wound area and the bird confined for an hour or two to allow the tissue to soften sufficiently so that the band can be removed. Assuming a strong likelihood that the injury will heal and the bird is to be re-banded, in most cases a larger band should be used and placed on the other leg, **never on the injured leg**. A note should be made in the records to report band replacement and explain the use of the larger band.

### 8.4. Data Collection and Measurements

All banders should collect data using standard techniques because only data collected in a standardized manner can be compared. Identification keys are based upon standardized measurement methods. The guidelines below describe the most applicable techniques for each measurement or character. Great care must be taken with measurements, as even experienced banders may not obtain the same measurement when measuring the same wing, for example, multiple times. Experience provides greater consistency. Banders have the professional obligation to pursue opportunities to work with other bander and compare measurements of the same bird to ensure standardization, measurement precision and self-calibration (see **Code of Ethics**, above)

Measurements by ruler or caliper usually require removal of the bird from the holding bag; the bird may be held in the Finger-tip Hold, Reverse Finger-Tip Hold or Banders' Grip for these procedures. Alternatively, the bag material can be moved around to permit access to the part (wing, tail, culmen) while the rest of the bird is restrained; **this must be done with great care** to avoid damage to plumage. The disadvantage to this method is that it does not readily permit watching the head of the bird for signs of stress. When calipers are used for measurements, they should be tested for accuracy on a regular basis. Over time, calipers can become damaged and inaccurate through use.

#### 8.4.1. Wing

The measurement is of the unflattened chord, from the bend of the folded wing to the tip of the longest primary (Figure 32). The bird may be held in the Finger-tip Hold or Banders' Grip with the thumb held away from the bird's side and the index finger placed along the top or bend of the wing, or in the Reverse Finger-tip Hold with the bird's underside rotated toward the bander. As noted above, banders with large hands need to be particularly careful that they do not inadvertently stretch the bird's neck. With practice and experience, many banders have found that the Finger Tip Grip can safely be used while measuring the bird. The wing rule or calipers should be positioned to contain the unflattened wing, starting with upper jaw gently against the bend of the wing. The calipers are then adjusted so that the lower jaw just touches the distal end of the longest primary feather. The wing must not be flattened during this process; doing so will bias measurement of the chord. This measurement should be omitted, or the other wing measured, if the bird is missing or replacing primary 9 or 10. These are the longest primaries, so if they are missing, growing, or have damaged tips, erroneous measurements will result. **N.B.** Some hummingbirds do not hold still enough for this measurement. No more than three attempts to measure wing chord should be made because of the risk of injury.

Figure 32. Measuring the wing chord - wing rule and caliper methods are both illustrated (photo Mary Ellen Kelly).



#### 8.4.2. Tail

The tip of a thin ruler is slipped between the two central rectrices near their bases and as close to parallel to the feather plane as possible, then pressed lightly toward the body until it stops. Record the length (to the nearest 0.5 mm) to the tip of the longest rectrices (Figure 33). Do not measure the tail if the longest rectrices are extremely worn, broken, missing, or growing. It is important to insert the end of the ruler into place between the two central rectrices by moving the measuring device *down from the rump/uppertail region* rather than up from the feather tips, which may cause damage to the feathers.

Figure 33. Measuring the tail (photo Lee Rogers).

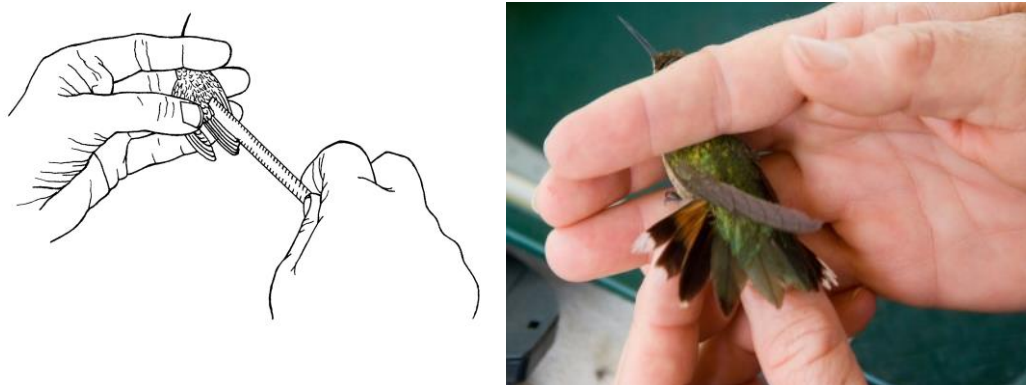

#### 8.4.3 Exposed culmen

Most published references to bill lengths are of the exposed culmen. This is the most difficult hummingbird measurement to take and it is important to make sure the measurement is started in the correct place. Calipers, preferably ones that read to 0.1 mm, are the best tool for this. The measurement is taken from the front edge of the feathers on the top (dorsal) side of the upper bill (maxilla) to the tip of the bill (Figure 34). In the case of birds with curved or decurved bills, this measurement is actually the chord

of the bill. Caution should be used not to damage the hummingbird's tongue if it protrudes from the tip of the bill. The method of measuring culmen has evolved over time and has been modified to improve hummingbird safety. The current design, described herein, is the recommended method to measure culmen. Using the **smaller** set of measuring arms on the caliper, and utilizing a “**one side over and one side under**” technique can avoid any pressure or injury to the tongue (Figure 34 and 35).

Figure 34. Measuring the exposed culmen, using the large “jaws” - **not the recommended method anymore** (photo: Milo Burcham).

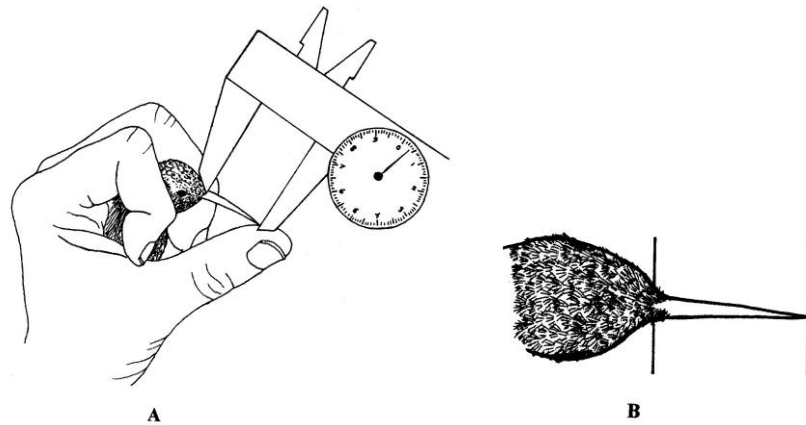
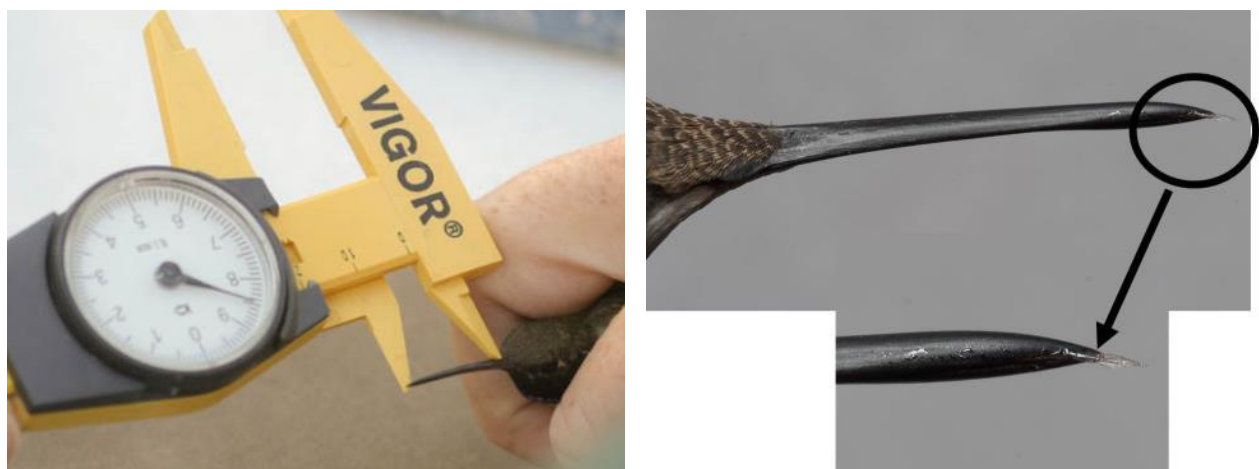

Figure 35. **The recommended method:** the “over and under” technique using the smaller set of “jaws”. This technique avoids touching the tip of the beak and any tongue that may be sticking out the bill tip (photo Lee Rogers).



## 8.5 Other characteristics

### 8.5.1. Bill corrugations

Young hummingbirds have fine corrugations extending diagonally along the length of the bill (Ortiz-Crespo 1972; Yanega et al. 1997) (Figure 36). Recognition of the extent of these bill features can permit identification of the bird as a young bird (HY or SY). Bill corrugations are difficult to see and require good light and a magnifying lens; an optical visor (see Appendix B) is excellent, and a good jeweler's loupe works well. A magnification of at least 10x is recommended. Faint corrugations at the base of the bill (proximal) should be ignored; fine lines on the distal 80% are the important character. The corrugations are most extensive and obvious on a very young bird; they wear off and are shed in extent as the bird matures, especially during the annual molt, when the outer layer of the bill is shed more rapidly. Banding with an experienced hummingbird bander greatly facilitates learning to recognize this feature.

Figure 36. Extent of fine corrugations on the bill. (A) side view of young bird with corrugations on most of the bill. (B) side view of older bird with corrugations only on the base. (C) & (D) dorsal photographs of young bird with fine corrugations.

(Photos: Anthony Hill)

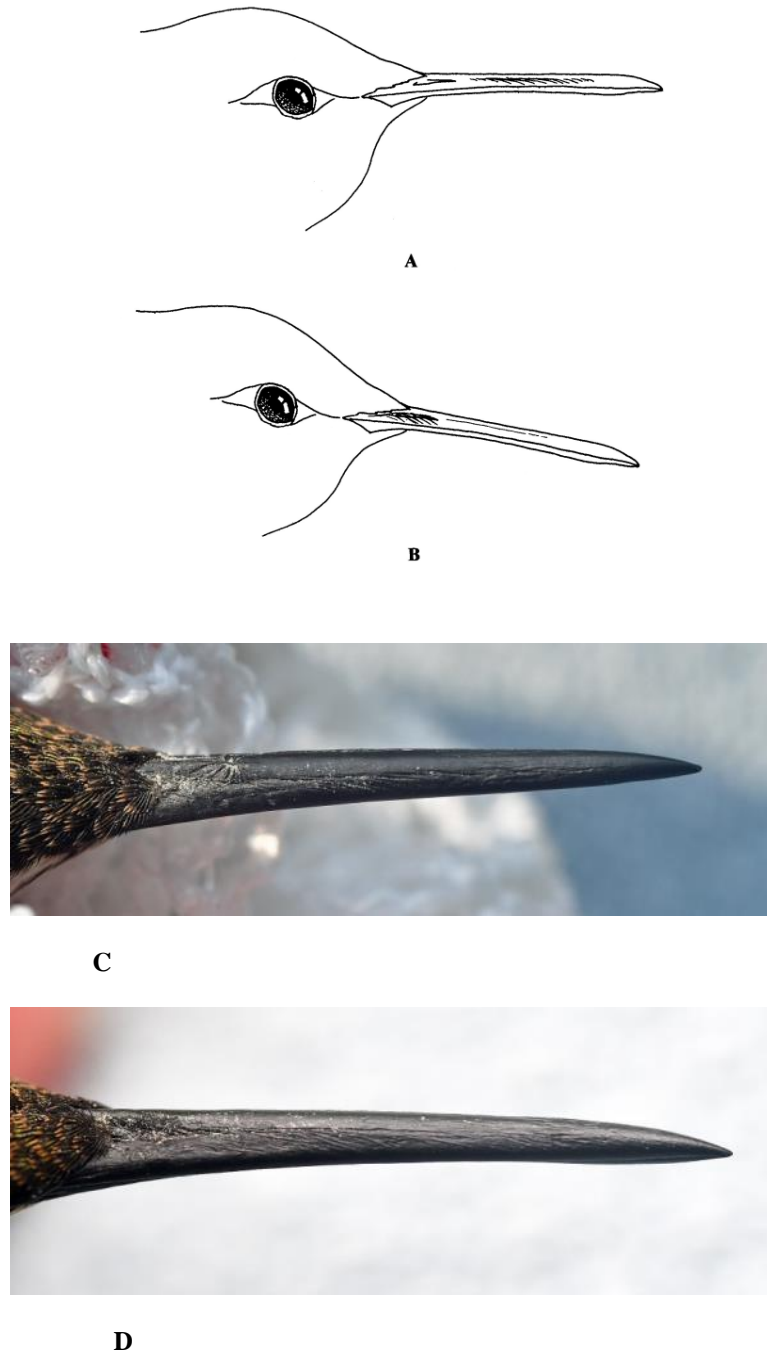

### 8.5.2. Iridescence in gorget and crown

Metallic iridescent feathers in the gorget (throat) or crown of an immature hummingbird may provide information useful in ageing the bird, and the sex in some species. Banders are urged to record these findings.

### 8.5.3. Feather shape and pattern

Primaries, secondaries, and rectrices often yield essential clues to species identification, ageing, or sexing. The key in [Appendix H](#) illustrates most of these characters. Especially when banding immature birds, these important characters should be examined and recorded in the banding notes. See the examples below for *A. colubris* to get a sense of what feather shape can look like (Figure 37). Note, this characteristic can be used on multiple species, the photos below are only an example.

Figure 37. Primary 6 tip of Ruby-throated Hummingbirds to distinguish the sex of HY birds. (photos: Anthony Hill)



*A. colubris* (RTHU) HY/F



*A. colubris* (RTHU) HY/M

### 8.5.4 Rectrix color

In immature *Selasphorus* the amount and distribution of rufous in the tail may indicate sex. This information should be made part of the banding records.

### 8.5.5. Cloacal protuberance

In many landbirds, the region of the cloacal orifice swells during the breeding season in males and extends outward conspicuously. This structure is called the cloacal protuberance. Both male and female hummingbirds have small protuberances throughout the year; since there is normally no conspicuous difference between the sexes, they do not need to be noted or measured. At the time of egg laying, females often show a noticeable swelling in the bare area anterior to the cloaca and the egg itself may be quite visible immediately prior to laying. During the breeding season, banders handling numbers of birds should check females to ensure that those with a visible egg are held only a short period and are handled with extreme care; some banders prefer to prioritize processing of breeding females over adult males, juveniles and obvious migrants.

### 8.5.6. Brood patch

Incubating birds of many species of landbirds develop a featherless, thickened, and vascularized area on the ventral surface. This brood patch touches the eggs during incubation and small nestlings during brooding and helps to regulate their temperature. Although the abdominal area of an incubating hummingbird appears little different from that of a non-incubating bird, many banders have noticed subtle to distinct swelling of the abdominal area that may be associated with egg development. Banders should examine closely the area anterior to the cloaca and take notes and photos on the nature and extent of its development because such studies may lead to means of recognizing an incubating or female bird.

The feathers are gently blown aside to examine the ventral area. A large diameter plastic drinking straw, cut to the bander's preferred length, is ideally suited for blowing back the feathers to check the abdominal area, as well as molt locations, presence, abundance and location of ectoparasites and extent of body fat.



### **8.5.7. Skull ossification/pneumatization**

The skull of many young birds in other species is single-layered and provides an accurate indication of age. Techniques for using the degree of skull ossification have not been developed for hummingbirds, since their tongue wraps around the top of their skull, blocking the field of view.

### **8.5.8 Body mass (weight)**

Body mass can be a useful indicator of physiological condition. Birds are heavier when they have fat deposits, when growing new, vascularized feathers, or when an egg is present in the oviduct. Mass can provide a useful index of body size when used in combination with the wing chord. When weighing a hummingbird, it should be placed in a (tared) bird bag or the cut-off toe of a light nylon stocking or a 'footlet' as described above or loosely wrapped in a scrap of transparent bridal veil or mosquito netting. The bag or other containment should be carefully folded over (and secured as necessary) to prevent bird escape during the weighing process. Other restraints such as tubes of clear plastic open at both ends, or any small, lightweight tube, may be used as long as the bird is restrained just long enough for accurate weight determination and with care taken to ensure the bird does not overheat. No method that would allow the bird to fly off with the restraint still attached, such as the 'cape' should be used. Weighing should take place on an electronic balance (preferred) or by use of a spring scale such as a Pesola scale. Given their small size, hummingbirds should be weighed in tenths of a gram. The tare weight of weighing bags and clips or other containers must be adjusted for accurate measurements. The calibration of balances or scales should be checked before each banding session and tare weights should be checked frequently during the banding session.

### **8.5.9 Other**

Use of keys for the birds in a particular area may lead to finding other characters that provide information useful in determining age and sex. By recording, discussing and publishing these details, banders may contribute to improved ways of determining age and sex of hummingbirds.

## **8.6. Color Marking**

An auxiliary marking permit for color marking birds is required from the appropriate banding office. For example, when regular trapping operations take place at the same location during the breeding season, birds that have been previously banded could be marked so that they need not be recaptured during that season. Marking birds without approval from the appropriate banding office is illegal. Color bands are not appropriate for use on hummingbirds due to the small, short tarsus. Nontoxic, water-based fabric paints, available in most craft and hobby stores, will stay on the bird for several months or until feather molt. Fabric paint comes in an array of colors, dries quickly even in humid weather and, if it dries usually can be reconstituted by adding water. The paint may be applied with a small brush by dabbing a small amount on top of the bird's head. Paint is not easily scratched or worn off the top of the head, nor does head painting interfere with the bird's flight. Care must be taken to avoid getting paint on flight feathers. Marking on the neck, breast, or abdomen may be appropriate in certain circumstances, but with all color marking, the impact of these highly visible areas on mating displays and selection is unknown, so color-mark minimally and with care.

## **8.7. External parasites**

Lice, their eggs (nits), ticks, and mites occasionally occur on hummingbirds. They are not known to harm them and should not be removed except when voucher specimens are required. Large, sedentary lice found under the gorget feathers provide a potentially useful gauge of the health of individual birds, which data in aggregate may reflect the health of the birds' environment. Recording the presence and abundance of these lice and their nits may prove useful for long-term population studies. Banders may want to participate in projects that require collecting and submitting parasites for examination. In some cases, an additional endorsement will be required on the bander's permit. Details can be obtained from the appropriate banding office.

## **8.8. Recaptures and Caution with Recaptured Females**

Recapture of Banded Hummingbirds: The bander or assistant must carefully read and record band numbers of previously banded birds. The number should be read twice, for correctness, and immediately written in the site record along with species, age, sex, and other appropriate detail such as weight and plumage condition. Careful reading and recording of the information is essential particularly for foreign recaptures.

A very important consideration whenever a female hummingbird is recaptured, even one banded earlier in the same year, is to carefully examine the band to look for any trace of nesting material that may have accumulated under the band. Magnification may be necessary to see the material. If any material is present, then it should be carefully removed using small sharp scissors (point slipped under the spider web), a needle, or tweezers. Often times there will be a tight, white ring under the band – this is usually a very tight ring of spider web silk, and it must be removed. Even if the bander collects only very basic data from recaptures, the bands on females must be carefully examined every single time a hummingbird is handled.

## **8.9 Banding nestlings**

Some banders will band nestlings as part of their study. There are excellent photos that Rusty Trump has on his website of nestling Ruby-throats – these can be used as a general guideline for aging nestling of other hummingbird species. [www.gahummer.org](http://www.gahummer.org)

Banders must wait until nestlings are large enough that the band will not slip off, but before the time they are expected to fledge (to avoid nest abandonment). This is generally a "window" of 11-16 days old. A rough estimate of when birds reach 12 days old, if exact hatch date is not known, is when their bill is visible over the edge of the nest, and their eyes are well open. Once they are ~11-12 days old, the tarsus is long enough to support a band and the leg has hardened off some so the band will fit comfortably. If banding is done too close to fledge date, the birds will jump out of the nest too early. The rate at which nestlings grow will depend on weather, species, and food availability.

### 8.10. Feeding Hummingbirds while banding

Birds that appear compromised at any time, or that have been held for more than 20-30 minutes, should be fed, and all birds should be given the opportunity to drink sugar water before release. Pre-release feeding is particularly important for longer banding sessions during which the birds' access to feeders is restricted. The feeding interval should be reduced if the birds appear to be stressed. A feeder of the type the birds have used should be placed on a small pan or plate adjacent to the banding site. At a busy station, one person should be assigned the responsibility of promptly feeding and releasing birds following banding. Experienced individuals can coax almost every bird to feed. The bird should be held in the Finger-tip Hold and the bird's bill should be held near, or just in, the feeder opening (Figure 38). With some feeder designs (e.g., tube styles), care must be taken to ensure that the bird's head is above the level of the liquid to avoid the possibility of sugar water running down the bill and into the nostrils (with potentially fatal consequences). If the bird does not feed immediately, it should be slowly moved back and forth before the opening and its bill allowed to touch the liquid. A bird may be stimulated to feed by blowing firmly on its face (like blowing the candles out on a birthday cake); bright light also can help, as moving bird and feeder from shade to full sunlight often provides the stimulus needed for a bird to drink. Some birds feed for a long time and may drink so much they can barely fly when they finish, while some birds may not drink at all. Force-feeding any bird has the potential to cause aspiration of liquid into the respiratory tract.

An alternative feeding technique used by some very experienced investigators is to **gently** pry just the tip of the bill open slightly, with the tip of an eyedropper or syringe holding sugar water. This method should only be used for birds that are conscious and able to hold their head in a normal upright position. Half of the tip of the bill (either mandible or maxilla is fine) is inside the dropper/syringe, the other half is outside. This takes fine motor control, and care must be taken to not put undue stress on the bird's bill. Then, a trace amount of sugar water is pushed into the bird's open bill (capillary action will draw the nectar into the bird's bill). This causes the bird to taste nectar, and if it is hungry, it will realize food is available and will then feed. Once the bird begins to lick, its bill should be retracted from the syringe (or eyedropper) and then the entire tip of the bird's bill (i.e. both mandible and maxilla) is inserted into the dropper or syringe, allowing the bird to feed. With practice, nearly every hummingbird can be coaxed to feed within a few seconds.

Hummingbirds when hand-fed normally just eat as much as they want (usually a couple hundred microliters of nectar—about the size of a raindrop). Occasionally however, for unknown reasons, a bird will begin to gorge (eating more than it should), and this puts it at risk of aspiration. If the bird seems to be taking an unusually large meal, retract its bill from the feeder/dropper/syringe for a few seconds, then offer it food again. If nectar appears at the corners of the bill, this is a sign of overeating; immediately remove the bird's bill from the feeder and do not offer it more food.

Figure 38. Feeding a hummingbird. Do not put their bills in any deeper – you should be able to see the tip of the bill, where it is in the fluid and see if the bird is feeding (photo: Anthony Hill).



### 8.11. Releasing

Great care must always be taken when releasing birds. The person holding the bird for release (in the Finger-tip Hold) should move away from the banding activity or other disturbances. The bird is placed on an open or cupped palm and the hand is held still until the bird flies away. Often a bird with its feet folded back toward the tail will not fly. Repositioning the bird with its feet in a

forward-facing ‘perched’ position usually results in flight. A gentle tap to the bottom of the hand holding the bird will usually spur a bird to flight. Release should always be in a direction away from any net or overhead obstruction such as an awning or shade tent. Any bird that remains in a releaser’s hand for more than a few minutes, even if it seems alert, should be given another opportunity to feed. A hummingbird must never be thrown into the air. If a bird does not fly readily when released, or if at any stage of the banding process the bird appears in distress, refer to [Section 7](#).

### 8.12 Documentation of Rarities

From time to time a bander may capture a highly unusual bird. It may be new for the area, be a hybrid, be present out-of-season or have unusual plumage or structural characters. Photographic methods and other techniques can facilitate a permanent record, but the data recorded are of primary importance. In addition to the basic information, any characters that will contribute to verification of the species should be noted and recorded. Banders should become aware of key characters of unusual species and the banding kit should include the references necessary to identify all North American hummingbirds.

A diagnostic feather, or portion of a feather, may substantiate the identity of a hummingbird. For this, a specific authorization for feather collection must be a part of the banding permit; this permission allows the removal feathers (or portions of them) from species that are not endangered or threatened. These feathers may be kept for the duration of the salvage portion of the permit, and then deposited with an institution with a possession permit. In addition to the authorization from the BBL, some U.S. states require banders to have specific permission to take feather material; be sure to check with the relevant agency. In Canada, banders must obtain either an authorization on the banding permit or a Scientific Permit from the regional office(s) of the Canadian Wildlife Service of Environment and Climate Change Canada.

The preserved feathers should bear diagnostic characters. For example, in the case of a female-plumaged Allen’s Hummingbird encountered in a geographic area where it is not expected, preservation of r5 would greatly supplement other data recorded to document the species. It should be kept in mind that a feather that has been gently plucked will soon be replaced, but a cut feather is not replaced until the annual molt (December-February in most North American species). Primaries should not be removed or cut; they are firmly attached and pulling them out may permanently damage the follicles from which they grow. Even cutting out a part of a primary could handicap a bird during flight. It is safer to clip the distal portion of a secondary than to pluck it. Rectrices and body feathers may be plucked, but with great care. Good quality, close up digital images are invaluable for documentation. Reference should be made to the NABC document regarding use of photography: <http://www.nabanding.net/photographic-guidelines/>

Details of these encounters, with photographs, should be published for the benefit of the ornithological community. It is strongly recommended that a good working relationship be established with the appropriate records committees. A working knowledge of the requirements for acceptance of such a group will be critical.

Information can be provided by photographs of a bird held in the following positions (in order of priority):

- gently spread tail illustrating the shape and coloring of the rectrices
- wing extended to show overall shape and stage of molt
- wing folded to show shapes and relative lengths of primaries
- side view of the head showing facial detail and bill characteristics;
- front view of the throat showing the pattern of spotting or gorget;
- top view of the crown and back and;
- breast, belly, and undertail coverts

## 9. DATA MANAGEMENT

For each bird banded, the banding offices require band number, species, species number, age, sex, banding location, and date captured. The details are explained in the Bird Banding Manual and in the Banders' Study Guide and banders must be familiar with these requirements. A daily journal should be maintained to include records of number and type of traps and nets used, hours of operation, weather conditions, names of banders and volunteers, a summary of each day's activities, unusual events, and the details of any casualties. Refer to the NABC Banders' Study Guide, which also includes a format for recording these details.

Hummingbird banders are studying species that are less well-known than many other birds banded in North America. Females and immature individuals of many species are very similar, so it is important for hummingbird banders to record data beyond the minimum required. Measurements and information on plumage characters provide a means of documenting species, age, and sex; notes on bill corrugations, molt, and cloacal/abdominal condition may reveal poorly known details of the life history.

Hummingbird banders are encouraged to record certain information on each bird. These data may be entered onto a sheet (coding form) with columns for each measurement or condition and a row for each bird. Ultimately this information can be used to submit banding schedules to the banding offices. The banding offices require schedules to be submitted electronically, which necessitates entry of your data into a computer. An alternative to writing data on a paper form (a coding form) is to enter data directly into a computer while banding. This is practical when at least two people are involved: one person bands and the other enters data. A well-trained "scribe" is a valuable member of the team, keeping the bander focused and on track to ensure that a complete and accurate data set is gathered for each bird. A bander with computer experience will find it simple to devise a computer database or spreadsheet to accept data in real time during banding operations or later from coding forms, but this is can be a challenge for the computer novice. Computer databases for banders are available; the Bird Banding Laboratory and the Bird Banding Office have such a program, called Bandit, and many individual banders have other programs. All banders must be familiar enough with computers to use programs such as Bandit. Any bander unwilling to acquire a minimal amount of computer expertise should enlist a volunteer to handle the data management.

Bandit is the computer program that has been produced jointly by the Bird Banding Laboratory and the Bird Banding Office. (See the BBL web site at <https://www.usgs.gov/software/bandit-software>.)

The Bandit program offers the following features:

- allows flexible data entry (including match with users field sheets; multiple entries);
- maintains band inventory;
- acts as a database and can summarize data in various ways;
- produces schedules and disc files for the banding offices as well as other reports;
- edits data as it is entered; can catch data entry errors;
- maintains a capture/recapture database;
- will accommodate up to 17 fields created by the user;
- available for PC and Mac computers

Users of Bandit software will be able to enter data on characters unique to hummingbirds and make their banding efforts far more productive. For field entry, a laptop computer or tablet is highly desirable for accuracy, and time saved, by avoiding transcription errors. Hummingbird banders are urged to record data on each of several characters. Although some characters may seem unnecessary or redundant, they provide a means of confirming species, age, and sex determinations and may prove useful in future studies. For example, if a question arises about the identification of a bird recorded as an immature male Black-chinned Hummingbird, the identification may be verified by looking at entries for number of iridescent gorget feathers, their color, wing and bill measurements, and the shape of the tip of rectrix 5. Recording data on bill corrugations and on the distribution of molt can be very useful in establishing events of an annual cycle. Banders should consider preparing a coding form applicable to the species expected in their study area.

Banders who do not use the Bandit program for direct data entry should use a database or spreadsheet program that can be easily imported into Bandit. The Bird Banding Manual should be consulted for details on reporting schedules in a timely fashion. A spreadsheet template in Microsoft Excel® has been developed by the BBL. This template uses the same field name descriptors and places them in the same order that the Bandit program requires. Use of this template to generate banding data sheets will greatly expedite the process of banding records to the BBL. See the link to the template at the BBL Bandit website. The Banding Offices require electronic submission of banding schedules exclusively, and the Bandit program simplifies this process by extracting the pertinent data from banding files and preparing it for electronic submission to the appropriate banding office.

## 10. PUBLIC RELATIONS, EDUCATION

Banding can be an excellent educational tool. Hummingbird banding offers a special opportunity to share the wonder of birds with others, including school groups, birders on a field trip, people visiting a publicized banding station, etc. Because hummingbird banding programs use nets or traps that are constantly tended, visitor interference with the banding operation is easily controlled, and under close supervision visitors—even children—can release birds. When visitors are present, give them information and the opportunity to participate.

Banding with the public carries with it a higher level of responsibility. For many visitors, a hummingbird banding session may be their only encounter with wildlife research, and the impression they take away, whether positive or negative, is likely to be lasting. Interpretation, whether by the bander or assistants, should be thorough and accurate, and at least one member of a banding team should be able to answer virtually any question from the public, from the recipe for sugar water to the value of banding studies and the biology and ecology of the birds being banded. This may give volunteers who are not comfortable with handling birds or recording data an opportunity for a positive contribution.

A visitor as young as three or four can release a bird. One approach is to instruct the child to clench the fist and hold it palm down to avoid reflexive grabbing. The bird is then gently placed on the back of the hand where it remains until flying off. In most cases the bird will barely be placed before flying away, but in the case of the occasional lingerer, the bander or an assistant should hold the child's hand to assure the safety of the bird. An alternative is to have the child hold the hand palm up and grasp the fingertips gently to prevent them from closing on the bird. If necessary, a gentle tap to the bottom of the hand will usually spur the bird to flight. Whenever visitors to a banding site are invited to participate in any way, their activities must be closely monitored to ensure the birds' safety.

During public banding demonstrations, the public education discussions should occur during the banding process because all birds should be released immediately after banding. Banded birds should not be held for any length of time waiting for the public to arrive for a demonstration. Fund raising during banding activities is not permitted by regulations and migratory birds should not be used for any direct fund-raising purposes. Adopt-a-bird programs where members of the public donate to have their pictures taken with a bird and then release it are not legal in the US and should not be practiced. Charging the public to witness a public banding demonstration should also be avoided. Banders can accept voluntary donations in association with a public banding demonstration. Canadian banders should determine the legality of these practices in Canada.

Because hummingbirds fascinate almost everyone, “show and tell” during banding presents an educational opportunity as long as it does not conflict with safe handling and expeditious release. Refer to Section 10, below. The North American Banding Council has published a guide to banding with the public; see: <http://www.nabanding.net/bander-resources/>. This document focuses on the use of mist nets, but many of the points are useful for banding in general.

## 11. LITERATURE CITED AND SELECTED BIBLIOGRAPHY

Refer to the Banders' Study Guide for a list of pertinent general references. The entire current library of *The Birds of North America* series may be obtained by subscription at <http://bna.birds.cornell.edu/bna/>. We realize not everyone has access to all these references. Please contact fellow banders for assistance in acquiring access to specific articles you're interested in viewing.

- Baltosser, W.H. 1987. Age, species, and sex determination of four North American hummingbirds. *North American Bird Bander* 12:151-166.
- Baltosser, W.H. 1994. Age and sex determination in the Calliope Hummingbird. *Western Birds* 25:104-109.
- Baltosser, W. H., and S. M. Russell. 2000. Black-chinned Hummingbird (*Archilochus alexandri*). No. 495 in Poole, A. and F. Gill (eds.). *The Birds of North America*. The Academy of Natural Sciences, Philadelphia, PA, and the American Ornithologists' Union, Washington, D. C.
- Baltosser, W. H., and P. E. Scott. 1996. Costa's Hummingbird (*Calypte costae*). No 251 in Poole, A. and F. Gill (eds.). *The Birds of North America*. The Academy of Natural Sciences, Philadelphia, PA, and the American Ornithologists' Union, Washington, D. C.
- Calder, W. A. 1993. Rufous Hummingbird (*Selasphorus rufus*). No. 53 in Poole, A. and F. Gill (eds.). *The Birds of North America*. The Academy of Natural Sciences, Philadelphia, PA, and the American Ornithologists' Union, Washington, D. C.
- Calder, W. A. and L. L. Calder. 1992. Broad-tailed Hummingbird (*Selasphorus platycercus*). No. 16 in Poole, A. and F. Gill (eds.). *The Birds of North America*. The Academy of Natural Sciences, Philadelphia, PA, and the American Ornithologists' Union, Washington, D. C.

- Calder, W. A. and L. L. Calder. 1994. Calliope Hummingbird (*Stellula calliope*). No. 135 in Poole, A. and F. Gill (eds.). *The Birds of North America*. The Academy of Natural Sciences, Philadelphia, PA, and the American Ornithologists' Union, Washington, D. C..
- Canadian Wildlife Service and U.S. Fish and Wildlife Service. 1977. *North American Bird Banding Techniques. Volume II*. Canadian Wildlife Service, Ottawa (parts revised, 1981).
- Canadian Wildlife Service and U. S. Fish and Wildlife Service. 1991. *North American Bird Banding. Volume I*. Canadian Wildlife Service, Ottawa and U.S. Fish and Wildlife Service, Washington, D. C. [The most up-to-date version is available on the internet at: <https://www.pwrc.usgs.gov/bbl/MANUAL/index.cfm>]
- Chavez-Ramirez, F. and A. Moreno-Valdez. Buff-bellied Hummingbird (*Amazilia yucatanensis*). No. 388 in Poole, A. and F. Gill (eds.). *The Birds of North America*. The Academy of Natural Sciences, Philadelphia, PA, and the American Ornithologists' Union, Washington, D. C.
- Hiebert, S.M, M. Ramenofsky, K. Salvante, J.C. Wingfield, and C.L. Gass. 2000. Noninvasive methods for measuring and manipulating corticosterone in hummingbirds. *General and Comparative Endocrinology* 120:235-247.
- Howell, S. N. G. 2003. *Hummingbirds of North America - The Photographic Guide*. Princeton University Press, Princeton, NJ
- Johnsgard, P. A. 1997. *The Hummingbirds of North America*. 2nd ed. Smithsonian Institution Press, Washington, D. C.
- Leberman, R. C. 1972. Identify, sex, and age it / key to age and sex determination of Ruby-throated Hummingbirds in autumn. *Inland Bird Banding News* 44:197-202.
- Martinez del Rio C., H.G. Baker, and I. Baker. 1992. Ecological and evolutionary implications of digestive processes: bird preferences and the sugar constituents of floral nectar and pulp. *Experientia* 48:544-551.
- McKenzie, P. M. and M. B. Robbins. 1999. Identification of adult Rufous and Allen's hummingbirds with specific comments on dorsal coloration. *Western Birds* 30:86-93.
- Mitchell, D. E. 2000. Allen's Hummingbird (*Selasphorus sasin*) No. 501 in Poole, A. and F. Gill (eds.). *The Birds of North America*. The Academy of Natural Sciences, Philadelphia, PA, and the American Ornithologists' Union, Washington, DC.
- Nur, N., S.L. Jones, and G.R. Geupel. 1999. A statistical guide to data analysis of avian monitoring programs. U.S. Department of the Interior, Fish and Wildlife Service, BTP-R6001-1999, Washington, D.C.
- Ortiz-Crespo, F. I. 1972. A new method to separate immature and adult hummingbirds. *Auk* 89:851-857.
- Phillips, A. R. 1975. The migrations of Allen's and other hummingbirds. *Condor* 77:196-205
- Powers, D. R. 1996. Magnificent Hummingbird (*Eugenes fulgens*). No. 221 in Poole, A. and F. Gill (eds.). *The Birds of North America*. The Academy of Natural Sciences, Philadelphia, PA, and the American Ornithologists' Union, Washington, D. C.
- Powers, D. R. and S. M. Wethington. 1999. Broad-billed Hummingbird (*Cynanthus latirostris*). No. 430 in Poole, A. and F. Gill (eds.). *The Birds of North America*. The Academy of Natural Sciences, Philadelphia, PA, and the American Ornithologists' Union, Washington, D. C.
- Pyle, P. 1997. *Identification Guide to North American Birds, Part I*. Slate Creek Press. Bolinas, California. 732 pp.
- Pyle, P., S.G. Howell, and G.M. Yanega. 1997. Molt, retained flight feathers and age in North American hummingbirds. In R. W. Dickerman, compiler. *The era of Allan R. Phillips: a Festschrift*. R.W. Dickerman, Albuquerque, NM.
- Ralph, C. J., G. R. Geupel, P. Pyle, T. E. Martin, and D. F. DeSante. 1993. *Handbook of Field Methods for Monitoring Land Birds*. Gen. Tech. Rep. PSW-GTR-144. USDA Forest Service, Pacific Southwest Research Station, Albany, California. 41 pp.
- Robinson, T. R., R. R. Sargent, and M. B. Sargent. 1996. Ruby-throated Hummingbird (*Archilochus colubris*). No. 204 in Poole, A. and F. Gill (eds.). *The Birds of North America*. The Academy of Natural Sciences, Philadelphia, PA, and the American Ornithologists' Union, Washington, D. C.
- Russell, S. M. 1996. Anna's Hummingbird (*Calypte anna*). No. 226 in Poole, A. and F. Gill (eds.). *The Birds of North America*. The Academy of Natural Sciences, Philadelphia, PA, and the American Ornithologists' Union, Washington, D. C.
- Schneider, K. J., R. G. Sagar, and H. B. Suthers. 1984. *An Introduction to Statistics for Bird Banders'*. Eastern Bird Banding Association.
- Scott, P. E. 1994. Lucifer Hummingbird (*Calothorax lucifer*). No. 134 in Poole, A. and F. Gill (eds.). *The Birds of North America*. The Academy of Natural Sciences, Philadelphia, PA, and the American Ornithologists' Union, Washington, D. C.
- Sokal, R. R. and F. J. Rohlf. 1981. *Biometry*. Second Edition. W.H. Freeman and Company, San Francisco.
- Stiles, F. G. 1972. Age and sex determination in Rufous and Allen hummingbirds. *Condor* 74:25-32.
- Tell, Lisa A., J. Hazlehurst, J. Brown, R. Bandivadekar, A. Spence, D.R. Powers, L.W. Woods, and A. Engilis, Jr. In preparation. Hummingbird (Family Trochilidae) Research Part 1: Welfare conscious handling and sampling techniques for live hummingbirds.
- Wethington, S. M. 2002. Violet-crowned Hummingbird (*Amazilia violiceps*). No. 688 in Poole, A. and F. Gill (eds.). *The Birds of North America*. The Academy of Natural Sciences, Philadelphia, PA, and the American Ornithologists' Union, Washington, DC
- Williamson, S. and T. Wood. 2000. Blue-throated Hummingbird (*Lampornis clemenciae*). No. 531 in Poole, A. and F. Gill (eds.). *The Birds of North America*. The Academy of Natural Sciences, Philadelphia, PA, and the American Ornithologists' Union, Washington, D. C.
- Williamson, S. *Hummingbirds of North America*. 2001. Houghton Mifflin Company, New York, 2<sup>nd</sup> Ed.
- Yanega, G. M., P. Pyle, and G. R. Geupel. 1997. The timing and reliability of bill corrugations for ageing hummingbirds. *Western Birds* 28:13-18.

## APPENDICES

<b>Appendix A - DESIGNING A RESEARCH PROJECT.....</b>	<b>47</b>
<b>Appendix B - BANDING EQUIPMENT, SOURCES, SUPPLIERS.....</b>	<b>49</b>
<b>Appendix C - INSTRUCTIONS FOR BUILDING TRAPS, HOLDING CAGES, AND BAGS.....</b>	<b>59</b>
<b>Appendix D - BANDING ASSOCIATIONS AND MEETINGS.....</b>	<b>78</b>
<b>Appendix E - LONG-TERM CARE AND REHABILITATION OF HUMMINGBIRDS.....</b>	<b>78</b>
<b>Appendix F - SKILLS AND KNOWLEDGE EXPECTED OF HUMMINGBIRD BANDERS.....</b>	<b>79</b>
<b>Appendix G - AN INSTRUCTOR'S GUIDE TO TRAINING HUMMINGBIRD BANDERS.....</b>	<b>81</b>
<b>Appendix H - A KEY TO WESTERN HUMMINGBIRDS.....</b>	<b>82</b>
<b>Appendix I - THE NORTH AMERICAN BANDING COUNCIL.....</b>	<b>92</b>
<b>Appendix J - OPTIONAL FIELDS FOR CODING HUMMINGBIRD CHARACTERISTICS.....</b>	<b>92</b>

## APPENDIX A. DESIGNING A RESEARCH PROJECT

Refer to Appendix C in the Banders' Study Guide for an example of a well-designed research project. To set one up and analyze data, you need not be a professional biologist, but you do need a rudimentary understanding of basic statistics (e.g., the mean, probability theory). Among other things, you can use statistics to determine average dates of arrival, significantly early or late occurrences, as well as the proportion of hatching-year birds to adults in a given population. Zar (1999) and Sokal and Rohlf (1995) are both good statistical textbooks, but they are not written for the lay-person. The Eastern Bird Banding Association produced an excellent introductory guide to ornithological statistics (Schneider et al., 1984). An excellent web site at the Patuxent Wildlife Research Center can provide software for estimating desirable sample sizes and analyses of some banding data (<http://www.mbr-pwrc.usgs.gov/software.html>; Nur et al. (1999)).

The "Methods" section of articles in journals like *North American Bird Bander*, *Journal of Field Ornithology*, *Condor*, *Auk*, and *Wilson Bulletin* provide guidance to well-designed research projects.

Project design proceeds through logical steps:

1. Ask a question. All well-designed projects focus on a well-defined question. This step usually implies some familiarity with the work of others. You can consult recently published literature at a large library. The BBL has an extensive literature list at their web site at: [www.pwrc.usgs.gov/rwp/database\\_descriptions.htm#PWRCbib](http://www.pwrc.usgs.gov/rwp/database_descriptions.htm#PWRCbib)
2. Develop a hypothesis. This combines the question with the expectation of what the answer might be, and why. Much necessary theoretical background comes from studying other investigators' results.
3. Design a project. Most people need help at this stage to design a workable project and determine what kinds of, and how many, data are needed. Here is where statistics help. Usually, the statistical test used to analyze the data dictates, to some extent, the types and sample sizes required for analysis. By now you should have a clearly formulated question, with a hypothesis, a plan for collecting the necessary data, and a plan for their statistical analysis. An experienced researcher or statistician can confirm that your proposed sample size and types of data are sufficient. Banders experienced with the capture of the proposed species should confirm that the target number and trapping method are easily attainable. Get other opinions on the possible limitations of a study; they could save a lot of hardship later.
4. Collect the data. This step should be relatively problem free if you have planned how to collect the data and received any necessary practical training.
5. Analyze the data. The use of a computer with data entry and statistical analysis programs makes analysis much easier.
6. Publish the results. Remember that "negative" results are just as important as "positive" results because they allow later projects to build upon them. Many publication outlets, from regional bird bulletins to international research journals, are available.

### A.1. Developing a Hummingbird Research Project

Banders can conduct research in two ways. They can analyze their own data or collaborate with others who have already designed projects (many of which may need skilled assistants). Many scientific studies can never be undertaken on an adequate scale by individual banders and are possible only as collective endeavors. Hence, even if banders have no specific project of their own, they can contribute to larger, organized projects. For leads to projects where you might help, contact the Banding Offices and check with researchers at universities and bird observatories, talk with other banders, and search for requests for assistance published in newsletters and journals or on the Internet. See the *Ornithological Newsletter* on the internet at <http://www.ornith.cornell.edu/OSNA/ornnews1.htm>.

To develop a research project:

1. Read extensively about hummingbirds, including the accounts in *The Birds of North America*. When questions come to mind, jot

them down; questions lead to research. Pick a question that intrigues you and then conduct a literature search. If the information you find does not satisfy you, design a project of your own.

2. Consider the species that you might study and do a literature survey on each one, so you have a comprehensive knowledge of them. Gaps in the knowledge of a species may lead to suitable studies. Do questions arise during your banding? If so, see if you can find the answers in the literature; if not, perhaps the question may become a study.
3. Conduct a comprehensive search to find existing projects already studying this question. Check with the Banding Offices, other researchers, banders who already have hummingbird permits, publications and the Internet. It is sometimes counterproductive to duplicate an existing project instead of collaborating and could possibly interfere significantly in another bander's research. Although replication of studies is the foundation of much of science.

The following possible research topics would require banding or marking of hummingbirds.

### **1. Determine migration paths, significant stopover sites, breeding ranges, and wintering ranges**

*Example.*—Anna's Hummingbirds in California are generally considered residents but no study has proven that individuals are present all year. Their post-breeding movement into the mountains has been documented, as well as migration to the south and east. Do they first go to the mountains, then move on to Arizona, and New Mexico and eventually return to their breeding area? Only one banding record exists as hard evidence of an Arizona to California migration route. Long-term banding projects might supply much needed information in both instances.

*Example.*—Long-term recapture data from Rufous Hummingbird studies have begun to confirm an elliptical, southeast-west-northward annual migration that was first suggested by Phillips (1975). The migration route of the Calliope Hummingbird seems similar; although relatively few captures have been reported along the migration route. More recaptures along this route are needed to indicate that the birds may follow the same route in successive migrations.

### **2. Determine how physiological and energetic constraints influence the behavior of migrants**

### **3. Relate body masses to time of day, time of year, weather, or flower availability**

### **4. Estimate population size and population turn-over (through mark-recapture studies)**

*Example.*—The impact of feeders and the presence of exotic plants appear to be beneficial to most hummingbirds, but no one as yet has determined the role of feeders in maintaining or expanding hummingbird populations. Some people maintain over 100 feeders; what is the impact of such large-scale feeding?

### **5. Monitor hummingbird and plant interactions**

A hummingbird in the hand offers an opportunity to obtain useful information on the floral resources it uses to "fuel" its energetically costly migration. Because migration and, later, reproduction may be limited by the availability of flowers along the "nectar corridor" that hummingbirds follow, we should learn which flowers hummingbirds visit and whether their availability is limited by natural variations in climate or by other effects, such as competition from introduced plants or spraying of herbicides. Banders are encouraged to: (1) Record the flowers hummingbirds visit near banding sites, noting their general condition and abundance. (2) Make herbarium specimens of the flowers of these plants for identification by botanists. If it is inconvenient to prepare herbarium specimens, simply place a few flowers in a labeled coin envelope. (3) Obtain pollen samples from banded birds for later identification by touching the sticky side of a 6-cm piece of acid free "Scotch" tape to areas around the bill, crown (avoid the eyes), chin, and other places you see pollen. Affix the tape to the inside of a small plastic ziplock bag and use a permanent marker to label the bag with hummingbird species, band number, location, date, time, and your name. If you know which flowers in the area are probably used by hummingbirds, list them. The Arizona-Sonora Desert Museum in Tucson, AZ, may provide pollen and flower identifications and coordinate information exchanges in Mexico, the U. S., and Canada. Contact them by e-mail at: [pol@desertmuseum.org](mailto:pol@desertmuseum.org); or at their web site: <http://www.desertmuseum.org> to inquire.

### **6. Study territorial behavior**

On breeding and wintering territories, study site fidelity, mate selection, dispersal distances, daily movement patterns, resource partitioning, and diet, and how all of these vary according to age, sex, and experience. Banding is crucial for identifying and following individuals.

### **7. Peruse "The Birds of North America" for suggested studies**

Much of the knowledge of North American hummingbird species is summarized in *The Birds of North America*. Included in each account is a section on Priorities for Future Research. Review these accounts to learn what work has been done and to gain ideas for your own study.

### **8. Compare sampling techniques used to estimate population numbers or habitat use**

Most hummingbird sampling is done at baited sites, but how the results relate to the birds' use of nearby habitats is unknown.



Capture rates of linearly set mist nets in different habitats could be compared. Ideally the research design would include a comparison with the results from baited sites. A study of this sort could lead to a design and protocol useful in establishing the importance of different habitats to hummingbirds.

### 9. Band hummingbirds as a part of a monitoring study

Few banders involved in the MAPS (Monitoring Avian Productivity and Survivorship) program or at constant effort stations band hummingbirds. Much could be learned if their skills were expanded to include the banding of hummingbirds.

## APPENDIX B. BANDING EQUIPMENT, SOURCES, SUPPLIERS

**Bags, holding.** Commercially available from Avinet Inc. (P. O. Box 1103, Dryden, NY 13053-1103; phone 1-888-284-6387; FAX 607-844-3915, e-mail [avinet@lightlink.com](mailto:avinet@lightlink.com), web page: <https://www.avinet.com/>) and AFO Banding Supplies (Box 1770, Manomet, MA 02345; phone 508-224-6521; FAX 508-224-9220, [http://afonet.org/wp\\_english/banding-supplies/](http://afonet.org/wp_english/banding-supplies/)) The material may be purchased from Nichols Net and Twine Co., Inc. 2200 Highway 111, Granite City, IL 62040. Telephone 800-878-6387, FAX 618-797-0212.

**Bags, Banding:** Order 6mm diamond mesh [https://www.ahh.biz/mesh/mesh\\_nylon\\_hex\\_6mm.php](https://www.ahh.biz/mesh/mesh_nylon_hex_6mm.php) . Instructions for making bags are in Appendix C.

**Band cutting tools.** Phil Arpke contact [Arpke.design@gmail.com](mailto:Arpke.design@gmail.com)



Band Cutting Tools: Lee Rogers contact [www.hummonnet.org](http://www.hummonnet.org) See Appendix C for more details.



Band Forming Tools: Lee Rogers: contact [www.hummonnet.org](http://www.hummonnet.org)



**Band stripping tool** is necessary to cut the plates of bands received from BBL into stripes of 10 numbers. A mini metal shear/brake is available from Micro Mark ([www.micromark.com](http://www.micromark.com)) 800-225-1066, item #84734) and is easily used to make exacting band strip cuts; a similar unit is available from Harbor Freight [www.harborfreight.com](http://www.harborfreight.com), item 90757. Note that the BBL now provides bands already cut into strips for banders who do not need large quantities per season (but a word of caution as sometimes the bands are cut too wide to safely use).



**Band Storage Pins.** Available for either Open or Closed Bands from Lee Rogers contact: [www.hummonnet.org](http://www.hummonnet.org) See Appendix C for instructions for making pins.

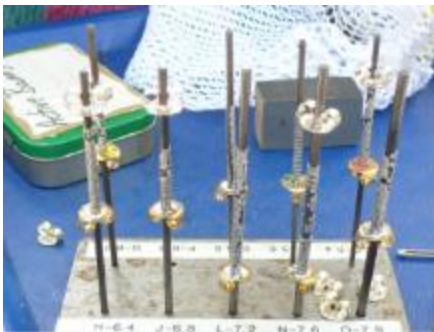

**Banding pliers.** Available from Lee Rogers: contact [www.hummonnet.org](http://www.hummonnet.org)



**Band-opening Needle.** Tapestry needles of various sizes, available at sewing and craft shops, are useful for opening bands.

**Cage-wire.** Traps last longer if made of “galvanized after welded wire.” It is available in a 1.0- x 0.5-inch (2.54- x 1.27-cm) mesh, 16-gauge wire in rolls 36-inches (91.4-cm) wide and in 100-ft (30.8-m) lengths, from Valentine, Inc., 4259 South Western Blvd., Chicago, IL 60609, telephone 1-800-438-7883; FAX 773-650-9099 (It is also available at Animal Stuff, LLC (Animal, Aviary,

Herpetological & Zoological Supplies) for details see <http://www.valentineinc.com/contactus.html>). Local hardware or farm supply stores are likely to carry this type of material

**Cage-wire clips and clip-closing tools.** Obtainable from Valentine, Inc. (Address above). If you plan to make many traps, you will find their catalog useful. Also known as 'J-clip' and available, with a dedicated closing tool, at many local farm/feed stores as well as Tractor Supply Inc. (Advantek brand, see: <http://www.tractorsupply.com/tsc/search/cage%20accessories>)

**Calipers.** Inexpensive nylon and metal calipers are available in Dial and Digital types.. Accuracy to 0.1 mm is recommended for measuring wing and culmen measurements and accuracy of 0.01 mm is required when making bands and adjusting band cutters. Calipers may be ordered from Forestry Suppliers (<https://www.forestry-suppliers.com/>) or [Amazon](#).

**Computer, laptop.** Some banders enter their data directly into a laptop computer at the banding site. Any model that operates a database or spreadsheet will be satisfactory if its display can be seen in the field. Even if you do not use a computer for field entry, you will need access to one for preparing and submitting schedules to the BBL or BBO via the Bandit program, referred to elsewhere in this Manual.

**Drop Screen Trap (Hall Trap).** Available from Lee Rogers contact: [www.hummonnet.org](http://www.hummonnet.org)

**Feeders.** There are many varieties. Unless you have large numbers of hummingbirds, a feeder with a small reservoir is adequate. Glass reservoirs are more resistant to sunlight than plastic models. Bases that come apart are easier to clean than single piece bases. Select simple models with a red base, into which the birds extend their tongues downward to reach the solution. The Dr. JB line (<http://drjbs.com/>) has proved especially popular because all parts may be safely washed in the top rack of a residential dishwasher. Best-1 glass hummingbird feeders are available for purchase on-line and in bird food stores with a variety of feeder bottle sizes. Perky Pet produces hummingbird feeders that are also widely available in stores specializing in bird feeders. And there are many other companies that make a good product too.

**Foods, special.** Nektar Plus may be obtained from Guenter Enderle Enterprises, 27 West Tarpon Ave., Tarpon Springs, FL 34689. Phone 727-938-1544. FAX 727-938-1545. NOTE: Nektar Plus (may only be available to licensed rehabilitators) spoils easily and should be used with care. Kits for growing your own fruit flies may be ordered from Carolina Biological Supply Co.; telephone 1-800-334-5551.

**Light, portable.** A battery-operated headlamp is useful on dark days or in poorly lighted locations. Available from sporting goods stores and by many mail order firms.

**Magnifying lens.** Some banders use a good jeweler's loupe, available from AFO Banding Supplies (see above), jewelry supply stores, the Nature Company, and other catalog houses. Flip-up binocular magnifiers that attach to an eyeglass frame are also effective; models are made by Donegan Optical Company, Inc., 15549 W 108<sup>th</sup> St., Lenexa, KS, 66219, and are available through many outlets, including Starr Gems (see under "Scales"). These lenses are excellent for observing bill corrugations and examining feather detail, injuries, and parasites. Other banders prefer a binocular visor attached to a head strap, available at sources cited above. One widely used instrument is OptiVisor, available from Donegan Optical Company. The Carson clip, available in several magnifications, has also proven useful (Carson Clip and Flip Multi Powered Clip-On, Flip-Up Magnifying Lenses OD-10, OD-12, OD-14). An eyeglass loupe is available from Baush and Lomb (<http://www.bausch.com/our-products/vision-accessories/professional-magnifiers/classic-metal-eyeglass-loupes>).

**Needle, knitting.** A #2 knitting needle (~2.75 mm), available at sewing supply or fabric stores, is useful for probing for the feet of a hummingbird in a holding bag, as well as for opening bands prior to use. A large paper clip, suitably bent, also may be used.

**Nets, mist.** Available in 6- and 12-m lengths. Most hummingbird banders prefer a mesh of 24 mm (measured across the long axis of a mesh opening pulled taut), but some banders use a 30 mm mesh without problems. Nets are available from AFO Banding Supplies (address under Bags, holding) and from Eastern Bird Banding Association. Nets also available from Avinet (see address under Bags, Holding).

**Poles, net.** Ten-foot (3-m) sections of EMT electrical conduit (inside diameter 0.5 inch [1.3 cm]) may be bought at hardware stores and make excellent and inexpensive support poles for nets. For convenience, they may be cut in half with a conduit cutter, available wherever conduit is sold. Drive poles into the ground with a "pounder" made from a heavy pipe about 24 inches (61 cm) long (inside diameter 0.75 inch [1.9 cm]) with a welded plug in one end. The device is similar to a fence-pole pounder used on T-shaped metal fence posts. Invert the pounder over the end of the conduit, then pound the pole into the ground with an up-and-down motion. Caution: do not take such long strokes that the pounder is lifted above the conduit pole; this could result in an injury. A second pole

may be inserted on top of the one in the ground with a 12-inch (30.5-cm) sleeve of copper pipe “M” (inside diameter 0.75 inch [1.9 cm]), or equivalent. Crimp the center enough to prevent it from sliding down the conduit pole. These sleeves may be cut from 20-ft (6-m) lengths purchased at the hardware store. Do not pound poles with a heavy hammer because the ends then flare outward and sleeves will not fit. Poles driven into the ground become clogged with earth, adding weight. Some banders drive galvanized electrical ground rods (or a section of 0.375-inch rebar) into the ground and place the conduit pole over the bar. Standard 8-ft (2.4-m) ground rods can be easily cut into three 32-inch (81.3-cm) lengths for the ground driven stakes. Grind or file freshly cut ends to prevent any jagged edges. If you use rods to support the net poles, you need a hammer; a 2-lb (0.9 kg) electrician’s mallet is excellent. Hardware stores may stock other types of rods that would function well.

**Rulers.** Use a thin metric rule 15 cm long to measure tail and other characters. Narrow stainless-steel rules are often found in stores that sell drafting supplies and in large hardware and supply stores, as well as from AFO Banding Supplies or Avinet (see above).

**Scales.** Readings to the nearest 0.1 g are adequate; no hummingbird in the United States exceeds 10 g. The simplest weighing device is a 10-g spring scale (Pesola is a well known brand), available from Avinet, AFO Banding Supplies (see addresses under Bags, holding), or Forestry Suppliers. Many hummingbird banders use small electronic balances available from jewelry and biological supply houses; Ohaus (<http://us.ohaus.com/us/en/home.aspx>) is an excellent brand. They are small, compact, and may operate on batteries. The Pocket Pro 150 made by Acculab is available from Starr Gems, Inc., (<http://www.silversupplies.com/index.shtml>), its capacity is 150 g, which makes it useful for larger birds. The Ohaus Model CT-200 series (measures weight to 0.01 g) and is battery operated, but you may not need the accuracy. Be sure that the scale or balance has a weight to use in calibrating it.

**Table, adjustable.** If you wish to use a wire cage trap at or near a feeder that has attracted birds, an adjustable table, such as a slide projector table, is indispensable. It can duplicate the height of the feeder in the cage or trap. One manufacturer, DA-LITE, makes a stand called Project-O-Stand (<http://www.da-lite.com/products/multimedia-carts-and-stands/projection-carts-and-stands/projectostand>); it is available at many camera and audiovisual supply stores and occasionally at flea markets and tag sales. As another option, you may be able to hang a trap with wire or support it with electrical conduit.

**Table, banding.** Folding tables with attached seats, available at sporting goods stores are very useful for field banding.

**Tarsus Gauge:** See next page for details. Lee Rogers contact: [www.hummonnet.org](http://www.hummonnet.org)

## Hummingbird Tarsus Gauge

The Hummingbird Tarsus Gauge (HTG) has 24 slots that increase in width by .065mm and is meant to measure the exact diameter of the tarsus. The edges of the correct slot should barely touch the skin on both sides. One slot smaller will obviously move the skin. One slot larger will be a bit loose. You will feel as much as see the correct fit. The premise is: If you can exactly measure the tarsus you can calculate the optimum band size for the individual hummingbird.



It requires two hands to measure the hummingbird's tarsus, one hand to hold the foot and the other to hold the gauge. The bird must be restrained in a mesh bag or other device that allows control of the bird while leaving both hands free to manipulate the gauge.

The hummingbird tarsus has an oval shape. Measure the longest dimension, front to back, about where the band will sit. The calculated band size is based on having the inside diameter of the band 0.5mm larger than the tarsus measurement. This amount of space is based on extensive work with Black-chinned hummingbirds and seems to work well with the medium and small birds. It is not enough space for the larger birds however. At this point we add one size for *Amazilia* and two sizes for *Lampornis* and *Eugenes*. The larger species appear to require proportionally more space between leg and band. This New Tarsus Gauge is capable of measuring most hummingbird species. Birds measuring slot sizes P through X may require addition space (+3 or +4 sizes) between band and leg. Additional research is required to determine optimum band sizes for the largest hummingbirds.

The goal is to find the optimum band size for the individual bird. Use your banding skill and knowledge to sanity check your measurements and choice of band size. Generally 'round up' for female birds since their tarsus tend to swell during breeding.

You can **practice** getting the feel of the Hummingbird Tarsus Gauge by using an **inter-dental brush** available at drug stores. **Standardize** your tarsus measurements by comparing with other banders to ensure consistency and accuracy of measurements.

Hummingbird Tarsus Gauge Translation

Slot ID	Band Size	Slot ID	Band Size
A	5.0mm	X	9.6
B	5.2	W	9.4
C	5.4	V	9.2
D	5.6	U	9.0
E	5.8	T	8.8
F	6.0	S	8.6
G	6.2	R	8.4
H	6.4	Q	8.2
I	6.6	P	8.0
J	6.8	O	7.8
K	7.0	N	7.6
L	7.2	M	7.4

The soft aluminum material that bands are made of is easily formed by the banding pliers to the shape of the hole. Banding pliers of unknown size can be tested to determine the exact size band they create by cutting a test band from a blank band strip (between numbered strips) equal to suspected size, forming, closing with test pliers, and measuring the outside diameter across both the x and y axis. Compare measurement to the table that follows (from Lee Rogers, Hummingbird Monitoring Network). See table below.

<b>Band Dimensions</b>					
Tarsus	Band Length	O.D. Circle	O.D. 1x Oval	<b>O.D 1.5 x Oval</b>	O.D 2x Oval
A	5.0mm	1.89mm	1.92 x 1.86mm	<b>1.94 x 1.84mm</b>	1.96 x 1.82mm
B	5.2mm	1.96mm	1.99 x 1.92mm	<b>2.01 x 1.90mm</b>	2.02 x 1.89mm
C	5.4mm	2.02mm	2.05 x 1.99mm	<b>2.06 x 1.97mm</b>	2.08 x 1.95mm
D	5.6mm	2.08mm	2.11 x 2.05mm	<b>2.13 x 2.03mm</b>	2.14 x 2.02mm
E	5.8mm	2.15mm	2.18 x 2.11mm	<b>2.19 x 2.10mm</b>	2.20 x 2.09mm
F	6.0mm	2.21mm	2.24 x 2.18mm	<b>2.26 x 2.16mm</b>	2.27 x 2.15mm
G	6.2mm	2.27mm	2.30 x 2.25mm	<b>2.32 x 2.23mm</b>	2.33 x 2.22mm
H	6.4mm	2.34mm	2.37 x 2.30mm	<b>2.32 x 2.29mm</b>	2.39 x .28mm
I	6.6mm	2.40mm	2.43 x 2.37mm	<b>2.44 x 2.36mm</b>	2.45 x 2.35mm
J	6.8mm	2.46mm	2.50 x 2.43mm	<b>2.51 x 2.41mm</b>	2.52 x 2.41mm
K	7.0mm	2.53mm	2.56 x 2.50mm	<b>2.57 x 2.48mm</b>	2.58 x 2.47mm
L	7.2mm	2.59mm	2.62 x 2.56mm	<b>2.64 x 2.54mm</b>	2.65 x 2.53mm
M	7.4mm	2.66mm	2.69 x 2.62mm	<b>2.70 x 2.61mm</b>	2.71 x 2.60mm
N	7.6mm	2.72mm	2.75 x 2.69mm	<b>2.76 x 2.68mm</b>	2.77 x 2.67mm
O+	7.9mm	2.81mm	2.84 x 2.78mm	<b>2.86 x 2.75mm</b>	2.87 x 2.75mm

**Band Storage Pins (Band size is in mm).**

Lee Rogers contact: [www.hummonnet.org](http://www.hummonnet.org)

**Storage Pins** can be made from **Numbered Drill Rod**, available from Granger [www.granger.com](http://www.granger.com) or on internet. They are exactly the same size diameter as the pins on your forming tool and will protect the shape and integrity of your bands.

The numbered drill rod comes in 30" or 36" pieces. A 3.5" segment of rod will hold 50 bands and fit into an Altoids tin. Use gun bluing on rods to help prevent rust. Polish pins with abrasive cloth after bluing to ensure metal is smooth and clean of residue. Large earnuts, jewelry supply, are drilled to fit individual pin size and used to cap each end. The earnuts are available in silver and gold finishes which can be useful for marking the beginning and end of a series. Inventory Dots can be used to label the earnuts with band size.



Band Size	# Rod for Open C Bands	# Rod for Closed Bands
5.4	49	54
5.6	48	53
5.8	47	1/16
6.0	46	52
6.2	44	51
6.4	43	50
6.8	41	49
7.2	37	47
7.6	35	44
7.9	32	43

## Adjustable Band Cutter

Verify the adjustment of the band cutter by cutting a test band from a blank strip. Measure the test piece with digital calipers capable of .01mm increments.

Use a ¼" wrench to **Adjust** the movable slotted plate.

Manipulate the two nuts on each bolt connecting the stationary plate to the slotted plate. To shorten the band length, loosen the outside nuts on the right side of the stationary plate and tighten the inside nuts on the left side. To lengthen the band, loosen the inside nuts and tighten the outside nuts. **Adjustable Band Cutter** The top slot is the smallest slot and can be adjusted as small as 5.2mm. The slot length increases by .2mm as they get closer to the operator.

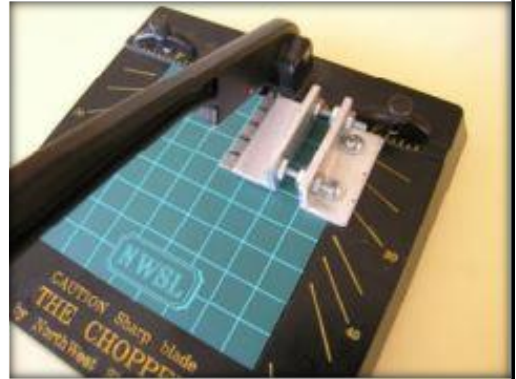

The slot closest to the operator is .6mm longer than the top slot. To ensure that the plate is square maintain the numerical relationship. (i.e. if the top slot is adjusted for 5.4mm the bottom slot should be adjusted to 6.0mm)

Once the tool is adjusted and the band size verified with blank material you can start cutting actual band strips.

**Recommended** width of band strip is 1.3mm. Strips must be  $\leq 1.5$ mm to fit into slots.

**Clean and Polish** the strip to remove any burrs or sharp edges. 600 grit wet/dry sandpaper works well to clean edges. For final polish use 1000 to 2000 grit sandpaper.

**Look** at the cutting pad and note the mark where the razorblade touches the pad. Place the strip flat on the cutting pad with the numbers visible and **upside down**. The letter preceding the lowest numbered band should be closest to the blade.

**Consult** the Hummingbird Banders Manuel for the appropriate place to make the initial trim cut.

**Manipulate** the band strip to the bottom edge of the slotted plate. Align the initial point over the cut mark on the pad and lower the cutting lever to make the first cut.

**Insert** the band in the appropriate slot and cut again.

**Double check** the first few bands to verify length and then go into **production**.

**Spot Check** to ensure calibration and adjust if necessary.

Use **Caution** when cutting the last band in the strip or anytime the fingers get close to the razorblade.



**Adjustable Band Cutter Maintenance:** Over time, depending on use and technique, the razorblade will cut a groove in the cutting mat. If the groove becomes too deep the band edge can be damaged. Check cut band edge for smoothness and sand appropriately. It is important to rotate the mat periodically to provide a fresh surface when groove becomes too deep.

**Rotate Mat:** Use a Philips screwdriver and wrench to remove the two bolts holding the adjustable bracket to Chopper base. Rotate cutting mat 90 degrees clockwise, so old holes in mat are in lower right-hand corner of Chopper. Turn Chopper upside down and mark the center of mounting holes on the underside of the cutting mat. Drill 11/32 holes in mat at the two marks. Replace adjustable bracket so that slotted plate is square to base a close to but not touching upper, ruled, edge. Adjust as usual for desired band length.

**Replace Razorblade:** Use a small Philips screwdriver to remove retaining bolt in handle, remove holding plate and blade. Replace with standard single-edge razorblade from craft or hardware store. Mount the replacement blade so that the cutting edge comes down squarely on the mat. Ideally entire length of the blades cutting edge will touch the mat at the same time. If inside part of the cutting edge touches first, remove blade from handle and adjust angle of cutting edge slightly. Remount and check.

## Numbers Down for Better Band Closure

**Hummingbird Bands** are photoetched onto sheets of 'dead soft' aluminum in groups of 100 with up to 300 numbers per sheet. These sheets are 'sliced' into strips with 10 band numbers and then 'diced' into individual bands at a length determined by the bander, formed into either an Open 'C' shape or a Closed ring, and placed on a Storage Pin or other medium until they are applied to the hummingbirds leg.

The thickness of the band material is 0.3mm so, remembering our High School Geometry, the circumference of the inside surface of a perfectly closed band is slightly smaller than the outside circumference. When the flat band material is cut to the desired length, and if the edges of the band are cut perfectly straight, as with scissors or flush-cutting dikes, the inside surface of the band will touch first when the band is applied to the bird, leaving a slight 'V' opening at the outer surface.

Similarly, if the band is cut with a razorblade the 'dead soft' aluminum material actually retains the impression of the tapered 'V' cutting edge of the razorblade. The result is that the bottom surface of the band is slightly longer than the top surface. When the band is cut with the numbers facing up a situation is created that exacerbates the closure problem.

We can use the slight bevel created by the razorblade cut to our advantage by cutting the band to length with the **numbers facing down**. This way the numbered surface of the band will be slightly longer than the inside surface of the applied band resulting in a smooth seam.

**Technique:** Using the Adjustable Band Cutter, maneuver the band strip, numbers facing up, to the bottom edge of the slotted plate. Align the initial point over the cut mark on the pad so that it is slightly before where the normal cut would be made and lower the cutting lever to make the initial cut. Keep the lever lowered with the razorblade touching the pad. Turn the strip over so that the numbers are down, slid the strip over to touch the razorblade, raise the lever and then slide the strip slightly under the blade. Cut off a small shard from the strip to set up the bevel on the letter side of the band. With the numbers still down slide the strip into the appropriate slot and make the final cut, creating the bevel on the number edge of the band. Form the band in your usual fashion and store for later use.

**Be careful**, especially when making shorter bands that the first bevel cut is made close enough to the letter edge of the band so that you do not damage the last digit when making the final bevel cut.

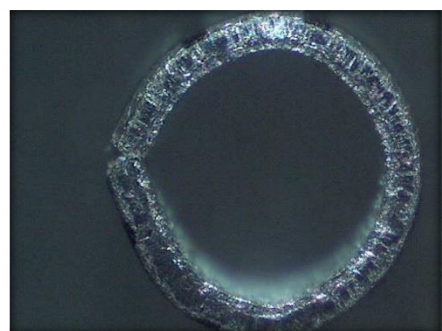

## APPENDIX C. DESIGNS AND INSTRUCTIONS FOR BUILDING TRAPS, NET TRAPS, HOLDING CAGES, AND BAGS

**NOTE that in many places there are both metric and imperial measurements, but if there is not, the conversion is 1 inch = 2.5 cm. For example, 3 inches = 7.5 cm (# inches multiplied by 2.5), and 15 cm = 6 inches (# cm divided by 2.5).**

### C.1. A Portable Drop-door Cage Trap

This is a cuboidal trap 18 inches (45.7 cm) on a side and made from 0.5-inch (1.3 cm) hardware cloth readily available in rolls 18 inches wide at most hardware stores. The design may be modified to use material available; the cage must be large enough to hold a feeder.

#### C.1.1. Materials list

- 10 ft 4.5 inches (3.2 m) of 18-inch (45.7-cm) wide galvanized hardware cloth; 0.5-inch (1.3-cm) mesh
- 44 plastic cable ties
- 6 inches (15.2 cm) of 1-inch (2.5-cm) wide hook-and-loop fastening tape (e.g., Velcro®)
- 1 flat lead weight (or equivalent)
- 2 hose clamps (0.375 inch; 9.5 mm)
- 1 pole to support trap; could use 5 ft (1.5 m) section of EMT electrical conduit
- 1 wire flower-basket hanger (or improvise)
- 8-24 inches (20.3-61.0 cm) of 0.25-inch (6.4 mm) wood dowel; the length depends upon the construction plan that is followed
- 1 piece of release line (nylon, monofilament, cotton, etc.; long enough to extend from trap to release point)

#### C.1.2. Tools required

- shears (or pliers) to cut hardware cloth
- scissors
- needle
- file, to smooth ends of wire
- pliers
- heavy thread

#### C.1.3. Instructions

1. Cut the hardware cloth into three 18- x 36-inch pieces (trap walls); save the remaining piece (16.5 x 18 inches [41.9 x 45.7 cm]) for the trap door.
2. In one of the large pieces, to make the door opening cut out a 12-inch (30.5-cm) square from one end so that it is 3 inches (7.6 cm) from the edge on three sides. Either file or grind smooth all sharp points to minimize injury to the birds and trapper.
3. Assemble the walls with at least five plastic cable ties per edge to form a cube. You may substitute metal clamps.
4. Attach the trap door with four ties or clips 1 inch (2.5 cm) above the door opening. The sides of the door should be even with the sides of the trap.
5. Attach three 2-inch (5.1-cm) hook-and-loop fastening tape strips to the lower edge of the inner surface of the drop-door (at corners and in center); attach the matching pieces opposite them on the outside of the trap. The tape is intended to keep the door closed after the trigger is pulled (because hummingbirds are very fast, they can escape through a bouncing door).
6. Attach a flat lead weight to the center of the exterior portion of the lower edge of the door to speed its fall. Some banders prefer to control the fall of the door by gently releasing the control line (see paragraph 10); they do not use the extra weight.
7. You may substitute strip magnets for hook-and-loop fastening tape or lead weights to speed the fall of the door and increase the likelihood of its sticking when it makes contact with the trap wall.
8. Attach hose clamps [sufficiently small to fit through the hardware cloth mesh and large enough to fit around a support pole (e.g., 0.5-inch metal EMT electrical conduit)] to the upper 1/8 and lower 1/8 of the center of the back wall of the trap. If you use a feeder to pre-bait birds, adjust the height of the trap to match that of the feeder.
9. Attach a flower basket hanger to the top of the trap; this will enable you to hang the trap from a tree limb, clothes line, or other support.

10. The mechanism to drop the door can be either above or below. The simplest below-door release mechanism is a 8-inch (20.3-cm) dowel rod (or equivalent) to prop open the door. Attach a string (nylon, monofilament, cotton, etc.) to the rod and run it through a counterweight (brick with holes works well) immediately below the trap on the ground and then to your hand. Figure 27 shows how to set the dowel. When the hummingbird enters the trap to feed, pull the string, thus releasing the door and trapping it.

For an above-door release, fasten a 24-inch (61-cm) dowel rod to the top of the trap, one end even with the back and the other end extending over the front. Screw a small hook into the front end and run a string through the hook to the door. See the plans for Sargent, collapsible cage-wire trap for details.

11. Customizing the trap might include cutting a round hole in a side wall large enough to allow you to reach into the cage to remove the hummingbird. Cover this opening with some type of fabric to prevent the hummingbird's escape. Netting sewn with an elastic cuff is one possibility. Some banders paint their traps to blend with the surroundings. For a trap that can be flattened for transport, cut six 18-inch (46-cm) squares from a 10.5-ft (3.2-m) length of hardware cloth.

A pull-door trap is believed less hazardous to the birds by some banders. It has a door that extends the width of the trap and is hinged at the bottom. The height of the door opening is a little less than the height of the trap. A line is used to pull the door upward to shut it; when closed, a weight on the end of the line may serve to keep the door shut until the captured bird is removed. The trapper controls the speed of the closing door.

12. Hummingbird feeders should be small enough to fit easily through the door and have perches from which the birds may feed. A perched bird is more easily captured than one hovering.

13. Some hummingbird banders have had good results with remote releases for traps, which can be constructed with easily obtainable electronic components by persons with some electronics expertise. These traps must be used with caution, as some birds will attempt escape when they hear the release and could potentially be caught in the door as it closes. This type of trap should not be used in attempts to capture rarities for the same reasons.

Example remote: will trip any door or drop any net, up to 100 feet away. The only construction required is to attach the receiver and solenoid to small board and add a 12 volt battery to power that (photo: Anthony Hill)  
[https://www.amazon.com/dp/B0033YECEK/ref=cm\\_sw\\_r\\_em\\_api\\_i\\_c\\_JfezCbEPPZ7H4](https://www.amazon.com/dp/B0033YECEK/ref=cm_sw_r_em_api_i_c_JfezCbEPPZ7H4)



#### C.1.4. Vertical Sliding Door Trap

A vertical sliding door trap is constructed in much the same manner except that the door is mounted on two 3/32 in. wires (piano wire) with a two larger diameter small plastic tubes epoxy-glued to the sides of the door (four small tubes needed) so that the door slides up and down on the runners to open and close the door. A fine cloth mesh (~1 in. wide) is applied across the bottom edge of the door and on the bottom edge of the opening. Door stops are placed at the bottom end of the vertical wires/door runners to prevent the door from completely closing. The mesh cloth closes the opening when the door is dropped and prevents potential injury to a bird that may unexpectedly leave or fly into the trap as the door is closing.

## C.2. Round Sliding-door (Cartwright) Cage Trap (Figure A)

### C.2.1. Materials list

- metal frame and hanging hook from 'pet-store' style bird cage: often the plastic bottoms and tops of these cages crack or break and they are discarded so they are easily re-purposed
- enough ¼" hardware cloth to line the inside of the bird-cage frame or make a cylinder in your chosen diameter, two round pieces with a diameter slightly larger than the cage for the top and bottom, and one square piece for the door
- garden mesh, or 24 mm mist netting: enough to line the inside of the bird-cage frame if you prefer this over hardware cloth
- 6"/15cm or smaller plastic zip ties
- metal cage clips (optional)
- 2 metal coat hangers
- 4 cotter pins with 'eye' large enough to fit over coat hanger
- monofilament line: 1 piece of monofilament line long enough to extend from trap to release point and extra for fastening mesh
- guide (see illustration) to run trapping line through
- 2-4 plastic twist ties used to close bread or garbage bags
- hook or length of chain to suspend feeder inside cage

### C.2.2. Tools required

- wire-cutting pliers
- electric grinder or a fine-toothed metal file (for smoothing cut edges)
- scissors if you are using mesh or mist netting to line the cage frame
- optional: work gloves

### C.2.3. Instructions

1. Remove damaged plastic top and bottom from bird-cage and set the cage on a flat surface. Remove and save the cage hanging hook: these usually have a ring or loop on top to hang the cage, and another hook underneath to hang a swinging perch.
2. Flatten hardware cloth on work surface and cut the following pieces:
  - one panel the same height as cage frame. Calculate circumference of frame and cut hardware cloth to same length.
  - two round pieces the same diameter as the cage frame
  - one panel approximately 0.5"/1 cm larger on all sides than the existing door opening
3. Smooth trimmed edges on all pieces to avoid injury to birds and trappers from sharp edges.
4. Roll the hardware cloth into a cylinder slightly smaller than the frame and place it inside the frame with the butted edges at the back of the cage away from the door.
5. Mark the door opening and remove the hardware cloth to cut out the door. Smooth the cut edges and replace the hardware cloth inside the frame. Fasten it with thin wire or monofilament line at the door and in several locations along the top and bottom of the frame. The butt ends can be fastened to each other and the frame with wire, line, or plastic zip ties.
  - 5a. To make this trap without the bird-cage frame, cut the door opening out of the hardware cloth while it is flat, smooth the edges, then fasten the hardware cloth into a cylinder and secure it with plastic zip ties where the ends butt together.
  - 5b. To make this trap with a mesh or mist net lining, cut a piece of material large enough to line the inside of the bird-cage and secure it to the inside of the cage with monofilament line, then cut out the door with scissors.
6. Use plastic zip ties to fasten top to cage every 2-3"/5-10 cm. Attach the cage hanging hook by feeding the bolt through a hole in the hardware cloth, centering it so the cage hangs level. The hook or length of chain which suspends the feeder will be hung here when the trap is complete but leave it out for now.
7. Cut the coat hangers along the sides that lead to the hanging hook. Leave at least 4"/10 cm on each side. Unbend them so the coat hanger is now shaped like a 3-sided square. Slide two cotter pins onto each hanger. Position the door between the hangers and slide one cotter pin over the door near the top and bottom of each side. You may need to pry the pins open a bit to get them over the hardware cloth.
8. Carefully bend the door slightly into a curved shape to match the outside of the cage. Position the door over the cage opening and use plastic zip ties or metal cage clips to secure the 'arms' of the coat hanger to either side of the door. Check to make sure the door slides up and down evenly and then secure the cotter pins tightly in position on the door with plastic zip ties.
9. Attach guide to top of cage above center of door with plastic zip ties. Attach the monofilament release line to the top of the door and feed it up through the guide.
10. Use plastic zip ties to fasten bottom to cage in two locations close together. Do not tighten the bottom ties completely so there is some room for the bottom to swing open. Use the plastic twist ties to secure the bottom shut.
11. Suspend a feeder from the center using the hook or adjustable chain, and hang the entire cage up. Check to make sure the weight of the cage does not create gaps where the top attaches to the sides. If it does, simply add more zip ties to close the gaps.
12. As with all drop door traps, do not release the door until the bird is well inside, preferably feeding. Remove trapped birds through the door opening. If the door sticks after being stored for the winter, rub the coat hanger 'slides' with a bit of lubricant.

Figure A. Cartwright Trap (photos: Cindy Cartwright).



### C.3. Collapsible Cage-wire (Sargent) Trap

This trap, made from 1.0- x 0.5-inch (2.5- x 1.3-cm) galvanized cage-wire, is 17 inches (43.2 cm) square and stands 36 inches (91.4 cm) tall; height may be modified as needed. A trap door is released remotely by a monofilament line. The trap may be permanent or collapsible. It may be suspended or placed on any flat surface. It is more durable than a hardware-cloth trap, but more expensive.

#### C.3.1. Materials list

- 8 ft 9 inches (2.67 m) of galvanized cage-wire: 1- x 0.5-inch (2.5- x 1.3-cm) mesh, 16-gauge, 36 inches (91.4 cm) wide. Galvanized after-welded wire is heavier, more durable, and more expensive than galvanized before-welded wire. Few hardware stores sell this wire.
- cage-wire clips: Valklips from Valentine, Inc.
- 18 inches (45.7 cm) of hook-and-loop fastening tape (e.g., Velcro®), 0.75 inch (1.9 cm) wide, with adhesive backing. Cut into six 3-inch (7.6-cm) strips
- 36-inch (91.4-cm) wooden dowel rod, 0.5-inch (1.3-cm) diameter; cut to 30 inches (76.2 cm) and 6 inches (15.2 cm)

- 1 small screw eye
- 1 piece monofilament line long enough to extend from trap to release point
- 1 piece coat hanger wire, to hang feeder in trap

### **C.3.2. Tools required**

- wire-cutting pliers
- electric grinder or a fine-toothed metal file (for smoothing cut edges)
- Valclinchler (a tool to crimp cage-wire clips, from Valentine, Inc. see contact information above)
- work gloves
- drill and small drill bit for making hole in dowel for screw eye

### **C.3.3. Instructions**

1. Flatten the wire on a work surface and cut six panels, each 17 x 36 inches (43.2 x 91.4 cm). Smooth all edges by trimming closely and grinding smooth. The grinding is critical for the safety of birds and handlers. Remember that you lose one rectangle of mesh each time you cut.
2. In one panel (front), cut out an opening 8 x 10 inches (20.3 x 25.4 cm), the 8-inch dimension 2 inches (5.1 cm) from one end and 4.5 inches (11.4 cm) from each side. Smooth edges.
3. In each of two panels (sides), cut out an opening 6 x 5 inches (15.2 x 12.7 cm), the 6-inch opening 6 inches from an end and 5.5 inches (14 cm) from each side. Smooth edges.
4. The back panel has no cuts.
5. From remaining two panels, cut three 17-inch (43.2-cm) squares for top, bottom, and false bottom. Smooth edges.
6. From the remaining 17- x 19-inch (48.3-cm) piece, cut out three pieces (doors), one 10 x 12 inches (25.4 x 30.5 cm), and two 7 x 6 inches (17.8 x 15.2 cm). Smooth the edges.
7. The trap is 36 inches (91.4 cm) high. Operate it upright. The openings in the three panels are near the top with doors wider and longer. Attach the top wire of each door to wire immediately above it, using wire clips. Using self-stick hook-and-loop fastening tape, place a “hook” piece on both sides of the bottom of each door by folding the hook-and-loop fastening tape over the bottom and back on itself, sticky sides together with the door sandwiched between the two sides. Place “loop” pieces in corresponding locations on the bottom edge of the openings in the trap. The hook-and-loop fastening tape catches the door as it closes, holds it to prevent bounce, and keeps the side doors secure.
8. Smooth the ends of the 30-inch (76.2-cm) and 6-inch (15.2-cm) dowel pieces to prevent splintering. Drill a tiny starter hole in one end of the long dowel and carefully insert the screw eye.
9. The panels may be transported unattached. For a temporary assembly, use bread bag twist ties. Twist tie the four sides together with the large door on the front, the two small doors on the sides, and the fourth panel on the back, but do not attach the final two panels. Twist tie one 17-inch (43.2-cm) square approximately 12 inches (30.5 cm) above the bottom. This is a false bottom and makes it easier to catch birds to remove them from the trap; it also raises the “catch area” when the trap is used on a low table. Fasten the remaining uprights together, then attach the bottom and top. Center the 30-inch (76.2-cm) dowel on top of the trap so that it extends outward over the larger opening through which birds enter, then fasten it with ties. Run a long piece of monofilament line down through the screw eye and tie it to the lower edge of the trap door; extend the other end to the operator, however far away that may be. Tie a 12-inch (30.5-cm) line to the 6-inch (15.2-cm) dowel, and tie the other end to the front of the trap just below the door opening. Use this dowel to prop the door open while you secure the end of the long line at the operator’s position (a clothes pin attached to a board works well to hold this end of the line). The short piece falls away when you pull the long line to raise the trap door. Hang a feeder that hummingbirds like in the trap with a piece of wire that can be fastened permanently to the top.
10. To make a permanent, nonfolding trap, use wire clips instead of twist ties to fasten the trap pieces. Some banders prefer a shorter trap made from wire 24 inches (61.0 cm) wide.
11. After baiting the trap and leaving the large door open, release the door only after a bird is well inside to lessen the chance of its flying out as the door is dropping. Remove birds through the smaller side doors.

### **C.3.4 A Modified Sargent/Drop-door Trap with Transfer Cage (Figures B, C and D)**

This trap made from 1.0 x 0.5-in (2.5 x 1.3-cm) galvanized welded wire (hereafter “welded wire”) offers sturdier construction (than hardware cloth depicted in the Drop-door design) as offered by the Sargent trap, and facilitates construction by using an 18-inch cube design (45 cm) made from readily purchased 36-in (90 cm) wide rolls of welded wire from which only three 18 x 36-in (45 x 90) pieces need to be cut. Each piece is bent at a right angle at its midpoint lengthwise and attached each to the other by clips or wire to form a cube as opposed to cutting and mating six sides, lessening the amount of cutting and filing to trim sharp projections.

In addition, an improved method of retrieving birds from the trap is offered in the form of a transfer cage (Figure B) attached to the trap wherein rather than reach into the entire volume of the trap to retrieve a bird (full arm extension and then some at times), the bird is guided into a 6 x 6 x 12-in (15 x 15 x 30-cm) enclosure from which it is easily retrieved by hand avoiding all the arm reach into the larger volume of the trap.

Since most trapped hummers tend to fly upward in a trap in an attempt to escape, this transfer cage is placed at the top of a

side of the trap (Figure C) to facilitate their removal from the trap.

**Construction** (in all cases where wire is cut, the sharp wire projections should be filed or ground smooth)

#### **Transfer Cage**

1. Cut a 12 x 25-in (30 x 63-cm) piece of welded wire with the 1-in wires running widthwise, trimming/filing the rough edges. Make a right-angle bend along that width at 6 in (15 cm), another at 6.5 in (16 cm) and a third at 6 in (15 cm) to form a four-sided enclosure requiring attachment with clips or wire where the two sides meet as in Figure B.

2. Select which will be the top side of the cage and from it cut the one-inch wires at their furthest extension from the cage, cutting those same wires on the other three sides nearest to the cage reducing the body size of the cage to 11 in (28 cm) in length.

3. Using those extended wires atop the cage, carefully bend each with needle nose pliers at mid-length at a right angle to allow the cage to form hooks to allow it to attach and hang from the edge of the trap.

4. Cut a 6.5 x 6-in (16 x 15-cm) piece of welded wire with the 1-in wires running widthwise for a door. Attach it at the back end of the cage with clips or wire loops allowing the door to swing inward.

#### **Trap**

1. Cut three 18-in (45 cm) wide pieces of welded wire from a 36-inch (90 cm) wide roll, and bend each piece 90° at the midpoint lengthwise and attach the three pieces with clips or wire to form a cube.

2. Select one side to be the front and at 2 inches (5 cm) down from the top cut a hole 8 inches (20 cm) wide and 12 in (30 cm) high centered on that side, i.e., 5 in (13 cm) in from each side as shown.

3. On either the right or left side (depending on convenience at the location where this trap will ultimately be used) cut a 5.5-in wide by 6-in long hole (14 x 15 cm), centered on the face of the side at the top of the trap.

4. Make two doors as follows from welded wire: 1) a door 10 in wide by 14 in tall (25 x 35 cm) to be attached to the outside of the front hole with clips or wire allowing the door to swing freely outward (the 1-in wires running vertically); and 2) another door which may be cut from the welded wire removed for the front hole 7 in high by 6.5 in wide (18 x 16 cm) to be attached on the inside of the trap at the side hole as depicted in Figure C.

5. To the top front of the trap attach a 5/8<sup>th</sup>-in (1.6-cm) hardwood dowel, 24 in long (60 cm) for use as a support for the front door. Since the door is 14 in long (35 cm), the dowel must extend out the same distance from the face of the trap. From a piece of wire form a hook with an eye and use a screw through the eye to connect the hook to the end of the dowel. On the inside roof of the trap hang a wire hook from which to hang a feeder centered 4-5 in (10-12 cm) from the back depending on the design/size of the feeder.

6. Two pieces of monofilament line, approximately 6-lb test (2.7 kg) need to be attached as follows. One piece about 40 in (1 m) long attaches to the inside door of the entry to the attached cage and with the door open, pass the monofilament out through the roof of the trap directly over the edge of the door, over the top and down the opposite side where it may be clipped to the trap with a pinch-clip clothespin. The second piece of monofilament is attached to the front door as illustrated and passed over the hook on the dowel to wherever the trap operator sits, typically 20-30 ft away (6-9 m), holding the monofilament trap line.

7. Lastly, the trap needs to be fitted with hook-and-loop fastening tape (Velcro brand) on the inside of the front door and on the front face of the trap to secure closure of the trap when the door is closed. Black tape 3/4-in (2 cm) wide is used. Tape that has adhesive on one side is not recommended because the adhesive is not very weather resistant. For the inside of the door, cut a 3-in (8 cm) strip of the hook tape and wrap it hook side toward the trap around four of the half inch wire in the position shown on the door in Figure C. Secure the hook tape with a 1.5-in piece (4 cm) of loop tape. Repeat this procedure at the second location on the door.

For the trap body, cut four pieces of loop tape 2 in long (5 cm) to be used in pairs, and cut four pieces of hook tape 1 in long (2.5 cm). At the positions on the trap body where the tape on the door would touch the trap, wrap a piece of the loop tape with loops facing outward and secure it with a piece of hook tape on the inside of the trap. Repeat this step again and twice more at the other side of the door and body.

#### **Trap Use/Operation**

This trap is used on a window ledge secured by an overhead guy line from atop the window. The open trap with feeder is constantly in place from beginning to end of season allowing birds to acclimate to it and use it daily. When not being used during a trapping session, the front door is secured in place by the hook on the dowel so that the door cannot accidentally close. The door leading to the transfer cage is closed.

During a trapping session, the front door is freed from the hook on the dowel, and opening and closing of the door is managed using the monofilament trap line from a chair 20-30 ft (6-9 m) away. When a bird enters the trap, the door is not closed until the bird has settled on the feeder and inserted its bill into the feeder. Most captures are singles, occasionally doubles and very rarely triples.

When a bird is caught, the monofilament operating the inside door to the transfer cage is pulled to open the door, the bird is guided into the transfer cage and the inside door closed behind it. Then from the other side of the trap a hand is gently inserted into the transfer cage to extract the bird. The trap is reset using a spring clamp to secure the trap line to the chair allowing other birds to use the feeder while the bird in hand is being processed.



Figure B. Sargent Trap (Robert P. Yunick)

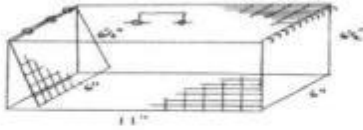

Figure C. Sargent Trap (Robert P. Yunick)

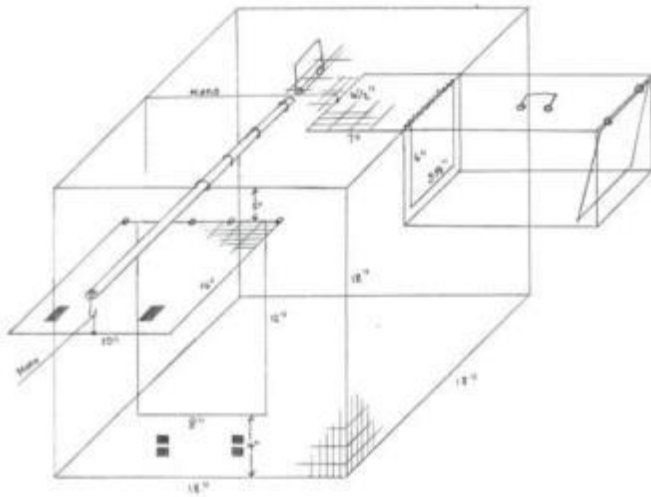
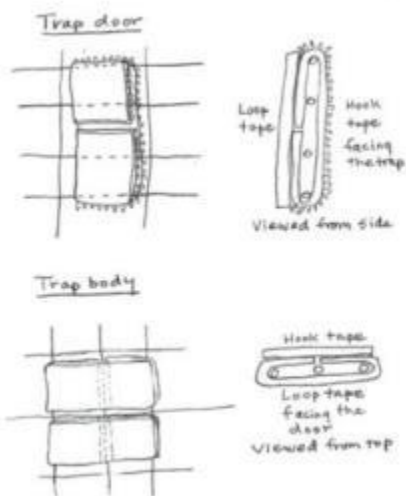

Figure D. Sargent Trap (Robert P. Yunick)



#### **C.4. Open-sided, Collapsible Netting Trap ("Hall" or "Bonnet" Trap)**

Bill Coughenour's original design has been modified by Bill Womack and Mike Hall. These plans were provided by Mike Hall. The directions are for a frame painted red, covered with red netting. While a red trap may attract birds, you may prefer to use a neutral color of fabric, leave the frame unpainted, and depend upon red in the feeder to attract birds. This type of trap is also available from Lee Rogers.

##### **C.4.1. Materials list**

- 25 ft (7.6 m) coil of 0.5-inch (12.7 mm) hard-surfaced, rigid-walled, plastic, hot-and-cold water pipe, such as Questpex
- 2 Questpex, brass, 0.5-inch Pex barb x 0.5-inch PB barb connectors (short pieces of plastic tubing the same size as the inside diameter of the water pipe may be used as substitute connectors)
- 3 PVC pipe tees, 0.5-inch, bottom leg of tee is threaded
- 3 iron threaded plugs, 0.5 inch
- 4 feet (122 cm) of clear vinyl tubing, 0.125 inch (3.2 mm) (inside diameter) x 0.1875 inch (4.8 mm) (outside diameter)
- 1 package of Stanley brand wood closet pole socket, 1.375 inch (3.5 cm)
- 6 feet (183 cm) of ice-maker tubing, 0.25 inch (6.4 mm) (outside diameter)
- 1 inch (2.5 cm) of ice-maker tubing, 0.25 inch (inside diameter)
- 1.5 pint (0.71 l) of bright red enamel paint (optional)
- 1 number 11 rubber "O" ring, 0.75 inch (19.1 mm) (outside diameter) x 0.5625 inch (14.3 mm) (inside diameter)
- 4.0-inch (10.2-cm) wooden dowel, 0.1875-inch (4.8-mm) diameter
- 6 steel eye hooks, 0.8125 inch (20.6 mm)
- 3 steel eye hooks, 1.1875 inch (3.0 cm)
- 1 tube Super Glue
- 1 spool monofilament fishing line, clear, 30- or 40-lb (~13-18 kg) test
- 3 black fishing barrel swivels, Size 3
- 1 single-foot fishing rod guide, Number 8
- 3 black interlock fishing snap swivels, Size 3
- 3 lead fishing weights, 2-oz (57-g)
- 1 package red hook-and-loop fastening tape strips (e.g., Velcro®), 0.5-inch or 0.75-inch (19.1 mm) wide
- 3 yards of red tulle fabric or a more durable fabric such as a fine-mesh insect netting in a neutral color
- 1 spool of red (optional) thread (one shade darker than fabric)
- 1 metal eyelet, 0.125 inch (3 mm)
- 1 bottle of Liquid Stitch permanent, clear-drying, machine-washable fabric adhesive
- 1 porcelain awning guide, 1.625 inch (4.1 cm) (outside diameter) (or substitute a similar size wood or metal ring with smooth sides)
- 1 plastic kite string winder (hand grip style)
- 1 16-oz hanging hummingbird feeder with perches
- 2 lengths of clothes hanger wire; 1 piece about 12 inches (31 cm); 1 piece about 28 inches (71 cm)

##### **C.4.2. Tools required**

- Electric drill
- Sewing machine
- Marking pen
- 0.125-inch (3.175 mm) drill bit
- Hand garden pruner
- Small hand awl
- 0.0625-inch (1.5875 mm) drill bit
- Cloth measuring tape
- Scissors
- Wire cutters
- Liquid dish soap
- Hard rubber mallet
- Paint brush
- Sand paper
- Needle
- Needle-nose pliers

##### **C.4.3. Instructions**

The **pull string guide** is assembled using the Stanley brand 1.375-inch (3.5-cm) pole socket. The package contains two sockets. Use the full socket, not the socket that is partially cut away along its bottom rim. On the underside of the socket, sand the

sharp edges of the rim until they are slightly rounded and no longer sharp. Paint the socket bright red using enamel paint.

Super Glue a 0.125-inch (3 mm) metal eyelet into the flat top center hole of the socket (Figure E-A). Turn the socket upside down revealing a larger counter sunk center hole (Figure E-B).

Using wire cutters, cut away the metal foot or band encircling the number 8 single-foot fishing rod guide. All that now remains is the round ceramic guide (Figure E-C).

Super Glue the guide into the counter sunk socket hole. The combination of a metal eyelet and ceramic guide will allow the trap's pull strings to run quickly and smoothly through the top of the trap.

With the socket still in the upturned position, screw one large 1.1875-inch steel eye hook into the interior side wall. When viewed from above, the threaded shaft of the hook is midway, top-to-bottom, in a horizontal position. The hook's eye is centered horizontally above and encircling the fishing rod guide. Remove the hook. Cut a short piece of 0.125-inch (inside diameter), clear vinyl tubing, just long enough to cover any sharp, exposed threads of the hook. Slide the tubing over the hook's threads and screw the hook back into position (Figure E-D).

Wrap a cloth measuring tape around the flat outside bottom rim of the socket. Measure, mark, and drill three 0.0625-inch pilot holes approximately 1.75 inches (4.4 cm) apart for the three 0.1875-inch, small, steel eye hooks. Screw the hooks into the socket's rim until the threads no longer show. When the lower portion of the pull string guide is completed and viewed from the underside, the small eye hooks are vertical, the large eye hook is horizontal, and the fishing rod guide is glued inside the counter sunk hole.

Turn the socket over. Screw two large 1.1875-inch steel eye hooks into the flat top of the socket. The hooks should be directly across from one another, on the center line, and near the outside edges. Screw the hooks in securely, allowing some threads to show. The pull string guide is now completed (Figure E-E).

Later, when the trap is strung, the three monofilament pull strings will be threaded up through each of the small, vertical eye hooks, through the large centered horizontal eye hook, through the fishing rod guide, through the metal eyelet, and out the top of the trap's pull string guide.

Make two **hoops**. The hoops provide the trap's basic structure. From coiled 0.5-inch plastic water pipe cut two pieces of pipe 67.5 inches (171. cm) long with a garden hand pruner. Bend the pipes into 21.5-inch (54.6-cm) diameter round hoops, measured outside-edge to outside-edge.

Connect both hoops using two brass connectors. Lubricate the threads of the brass connectors with liquid dish soap. Drive the connectors into the pipes using a hard rubber mallet. Push the other end of the connectors into the pipes to complete the hoops. With the hoops held horizontally, measure, mark, and drill three 0.125-inch vertical holes through each hoop (Figure E-F). The holes should be centered, vertical, and an equal distance apart, approximately 22.5 inches (57.2 cm). Adjust the distance between the holes to the size of the hoops. Prepare the hoops for painting by sanding them lightly. Paint the hoops with bright red enamel paint.

If one hoop is slightly larger, use it as the top hoop. With the top hoop in a horizontal position, make three small pilot holes on the inside center of the hoop. Each hole should be offset about 0.25 inch (6.4 mm) from the 0.125-inch vertical holes. Screw in three 1.1875-inch small steel eye hooks horizontally into the pilot holes until no threads show. When viewed from above the eye hooks are screwed horizontally into the hoop's center.

The three **counterweights** are made from 0.5-inch PVC pipe tees. The upright or bottom leg of the tee is threaded to accept a metal plug. Sand the tees to remove any sharp edges. Screw a 0.5-inch iron threaded plug into the vertical leg of each tee. Paint the tees with bright red enamel paint (Figure E-G).

Cut a 2-inch (5.1-cm) long piece of red hook-and-loop tape (hook part) and glue it on the back or top of the tee using Super Glue. Drill a 0.0625 inch hole at the top edge of the tee, above the metal plug, opposite the Velcro. Thread and tie off a 3-ft length of 40-lb (~18 kg) test monofilament fishing line through the 0.0625-inch hole. Repeat for remaining tees. **Note:** If you have never tied monofilament line, ask how. Monofilament is very "slick" and comes untied easily. Wet the monofilament when tying to help it slide smoothly, and, once it is dry, glue the knot with Duco cement or an instant glue.

Make the **fabric curtain** by cutting a 71-inch (180-cm) long x 35-inch (89-cm) wide piece of red tulle fabric (Figure E-H). Sew the 35-inch ends together to make a cylinder that is 35 inches high and 71 inches in circumference. Fold down 1 inch (25.4 mm) at both the top and bottom edges, stitch to form 0.5-inch (12.7 mm) pockets. The pockets will later accept a top drawstring and a bottom hoop of ice-maker tubing.

Lay the bottom hoop on the remaining piece of tulle fabric. Cut a circle outside the hoop large enough to wrap over the edge of the hoop and sew a seam. Sew around the inside edge of the hoop about 1-2 inches (2.5-5.1 cm) in from the inside edge. Trim away the excess fabric. The fabric should cover the hoop tightly.

Make a top **drawstring** by tying an 8-inch (20-cm) long piece of 40-lb (~18 kg) monofilament line to a rubber "O" ring. Drill a 0.0625-inch hole through the side of a 4.0-inch (10.2-cm) length of 0.1875-inch wooden dowel, centering the hole. Thread the other end of the monofilament line through the hole in the dowel and tie it off. Work the dowel through the 0.5-inch pocket at the top of the curtain, gathering the material and assuring the "O" ring remains outside the end of the seam (Figure E-I).

Thread the 72-inch (183-cm) length of 0.25-inch (outside diameter) ice-maker tubing through the sewn 0.5-inch pocket at the bottom of the curtain. Adjust the size of the finished loop so it will fall easily around the bottom hoop of the trap, and connect the two ends of the tubing by sliding them into a 1-inch long section of 0.25-inch (inside diameter), 0.375-inch (outside diameter) ice-maker tubing (Figure E-J).

The three **vertical uprights** are made using 0.125-inch (inside diameter) x 0.1875-inch (outside diameter), clear vinyl tubing. Cut three 15-inch (38-cm) long lengths of tubing (Figure E-K).

String **the trap** using 40-lb (~18 kg) test monofilament line. Cut three 2-ft lengths of line. Tie a size 3, black fishing barrel swivel on the end of each line. Run the three lines up through the holes in the underside of the bottom hoop and out the topside of the hoop's holes. Make a knot at the far end of the lines and push the lines through the 15-inch lengths of tubing, using a straight portion of clothes hanger wire. Slide the counter weights over the vertical uprights. Feed the line for the vertical uprights through the underside of the holes in the top hoop and out the top hole. Tie off the lines, wrapping them around the top hoop several times, to complete all three 15-inch vertical uprights. Trim off any excess line.

Cut three 2-ft (61-cm) lengths of monofilament line. Tie them through the same holes in the top hoop where the vertical uprights were tied. Double the lines through several times before tying them off. String the lines to the base of the vertical eye hooks in the bottom of pole socket's rim. Tie off the first line to the base portion of a hook, not to the eye of the hook. Measure the line's length approximately 9.75 inches (24.8 cm) from the socket to the outside edge of the top hoop. Tie off the remaining two lines at the base of the other two hooks, so that the trap hangs level. This takes some adjusting. With completion of this step, the pull string guide is connected to the trap's top and bottom hoops. If the trap does not hang perfectly level, it should not hamper the trap's operation.

Thread the three counter weight **pull strings** through the small hook eyes in the bottom of the pull string guide, then through the three horizontal eye hooks screwed into the inside center of the top hoop. Next, thread the pull strings through the large, centered, horizontal eye hook, through the fishing rod guide, through the metal eyelet, and out the top of the trap's pull string guide (Figs. 28D, E).

Bring the counterweight pull strings together and tie them off to a size 3, black barrel fishing swivel. The swivel should be tied off about 2.5 inches (6.4 cm) above the top of the pull string guide.

Tie a 6 m length of 40-lb (~18 kg) test monofilament line to the other end of the barrel swivel to create the trap's pull string. Tie the other end of the line to a plastic kite-string winder (hand grip style) for ease of handling. The pull string's length may be adjusted.

Drape the curtain over the top of the trap. Draw the top drawstring snug at the base of the pull-string guide. When the curtain is snug, trim the dowel on both ends to shorten it to 1.5 inches (3.8 cm), and slide it through the "O" ring to hold the curtain in place.

Adjust the curtain down the length of the trap until it hangs naturally. Cut three 8-inch (20.3-cm) lengths of hook-and-loop tape (the side with loops). Where the lowered counter weights match up to the curtain's base, wrap and mold a piece of tape around the curtain's bottom hoop (ice-maker tubing), matching tape ends approximately 4 inches (10.2 cm) up on the netting. Glue the tape vertically to both the inside and the outside of the curtain's wall with Liquid Stitch fabric adhesive. Stitch the ends together through the curtain (Figs. 28L, M). After the curtain's loop tape is connected to the counter weights' loop tape, adjust the curtain's length and raise it with the drawstring (Figure E-N). When the drawstring is released the trap is sprung and the curtain is dropped to capture the hummingbird (Figure E-O).

The **feeder hanger** hangs inside the trap. Bend an 8-inch (20.3-cm) piece of straight clothes hanger into a "∩" shape on one end and a "∪" shape on the opposite end. Sand the wire's ends to remove any sharp edges. Next, bend the same wire to fashion a gently flowing "C" shape. Hang the wire over the threaded shaft of the horizontal eye hook in the top inside the pole socket. The hook's threads are already covered with clear vinyl tubing so the wire will not damage the threads. Bend a 3-inch (7.6-cm) piece of straight clothes hanger wire into short "∪" shaped hooks on both ends. Next, bend one "∪" shaped end around the bottom of the "C" shaped hanger (Figure E-P). Sand any sharp edges and cover the short "∪" shaped hook, where the feeder will hang, with a length of 0.125-inch (inside diameter) clear vinyl tubing. Hang a hummingbird feeder from the small hook inside the trap.

Make a **trap hanger** from clothes hanger wire (Figure E-Q). Bend the wire so that the porcelain awning guide hangs directly above the trap's pull-string guide. Run the trap's pull string through the porcelain guide. Pull the trap's pull string to raise and lower the trap's curtain.

Make **stabilization weights** by tying three 12-inch (30.5-cm) lengths of 40-lb (~18 kg) monofilament line to three size 3, black interlock fishing snap swivels. On the opposite ends tie off three 2-oz (57-g) lead fishing weights. Snap the weights onto the barrel swivels at the base of the uprights to stabilize the trap during windy conditions.

Figure E. The Hall trap: (A) flat top of socket; (B) underside of socket with counter-sunk hole; (C) single-foot rod guide (left) and guide with metal foot cut away (right); (D) pull string guide: exploded side view—large eye hooks on top and small eye hooks on bottom; (E) top of pull string guide; (F) top view of hoop: vertical 0.125-inch hole and horizontal offset eye hook; (G) counterweight with monofilament line and 0.125- tubing vertically upright through center; (H) fabric curtain; (I) draw string threaded through top, sewn-in pocket of curtain (Mike Hall).

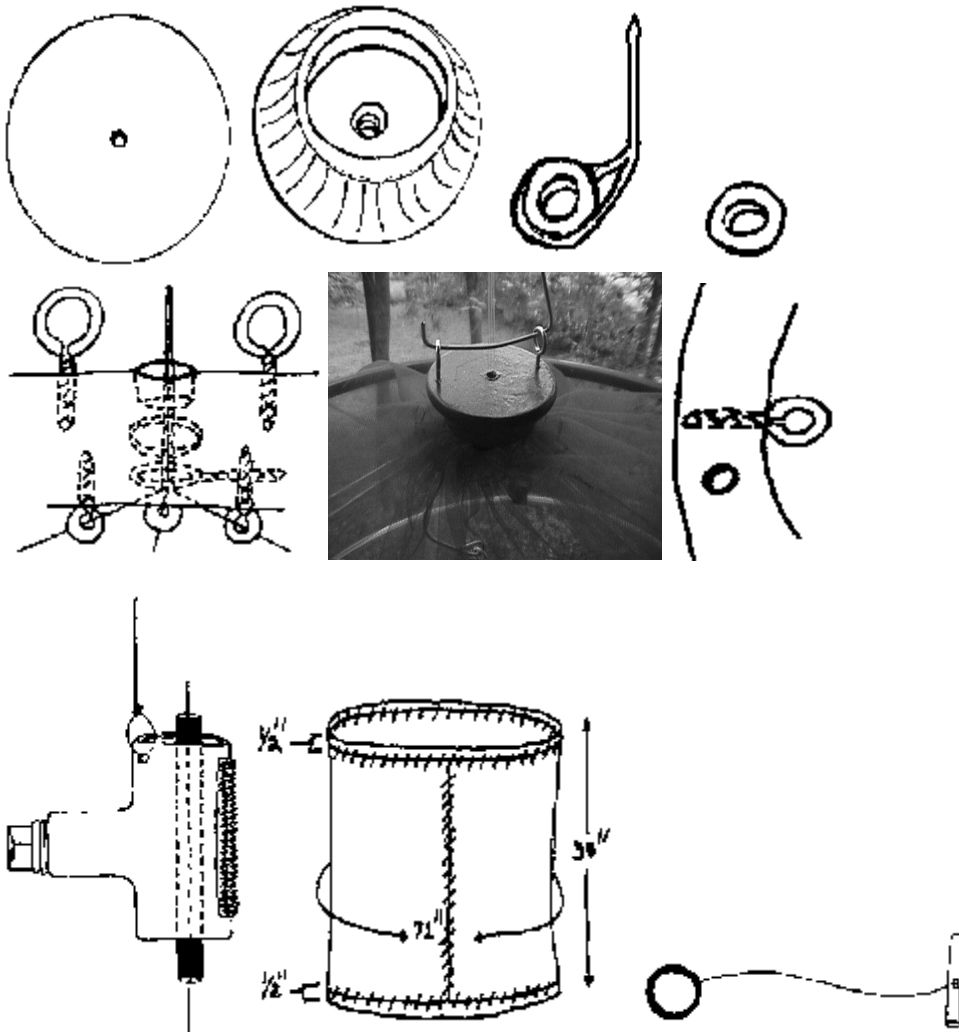

The Hall trap (contd.): (J) tubing (0.25-inch (0.1 cm), outside diameter) slipped inside a 1-inch piece of 0.25-inch (inside diameter) tubing connector; (K) vertical upright, line through bottom hoop and tubing, barrel swivel attached below the hoop; (L) curtain with hook and loop fastening tape attached to the counter weight; (M) detail of curtain with hook and loop fastening tape attached to the counter weight; (N) curtain raised; (O) curtain lowered; (P) assembly of the feeder hanger; (Q) pull string through top of pull string guide, then through porcelain awning guide (Mike Hall).

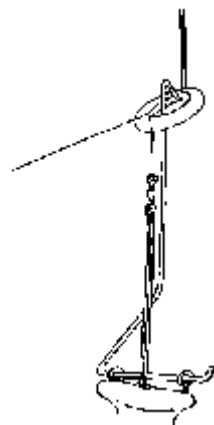
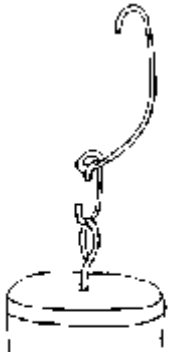
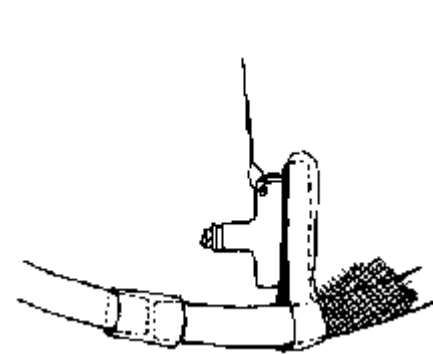
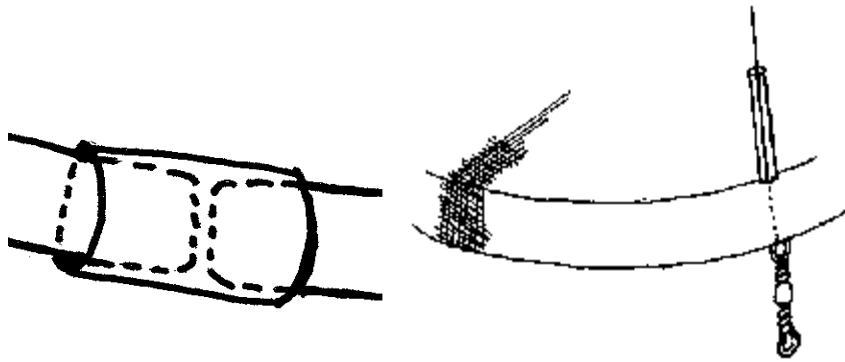

#### C.4.4 Hall-Taylor variant

The Taylor modification uses the same trap design but the weighted ring does not drop all the way to the trap base/floor. Instead, small black 3" (7.5 cm) plastic tubes are installed on the three vertical wires to stop the weighted ring above the trap base/floor. A mesh net is installed around the weighted ring and secured to it. The circular mesh net is measured to reach the base/floor of the trap when the trap is closed. The purpose of this important modification is to prevent potential injury to a bird unexpectedly leaving or entering the trap as the trap is closed. The Hall-Taylor variant trap functions in the same manner as described below.

#### C.4.5. Instructions for using the trap

Hang the feeder approximately 1 inch (2.5 cm) above the bottom of the trap. Pull the sides of the trap up about half the distance of the feeder's height. Make certain that the trap's strings are running freely and smoothly. The trap's curtain must run fast to catch hummingbirds.

Start trapping by allowing the bird to sit on the feeder's perch before springing the trap. The trap will require some break-in time. Nevertheless, this trap is fast. Once the trap is broken-in and running smoothly, it should easily catch hummingbirds on the fly, without the necessity for the bird to sit on the feeder's perch.

To collapse the trap, remove the hummingbird feeder and allow the trap to flatten down onto itself. **CAUTION:** Heavy wind and hail can shred the trap's fabric.

#### C.4.6 Rogers variant

The soft sided, drop screen trap is an effective and gentle method of catching hummingbirds that come to feeders. Birds may approach the central hanging feeder from 360 degrees and may come and go unrestricted until the trap is triggered, either manually or remotely. Birds are retrieved by reaching under the curtain and placed into holding bags for transport to the banding table.

The earlier Bonnet and Hall traps inspired many follow on variations and continuous improvements along the way. Important bird safety innovations by Bill Taylor moved the support strings to the outside of the curtain and a mechanism to stop the falling weight before they hit the bottom so a bird could not be injured by the weight.

Put together the four components before assembling a trap. The hanger assembly, the top surface, bottom surface, and curtain. The hanger assembly supports the trap and feeder. The continuous wire of the of type clothes hangers used by dry cleaners to hang pants, with the cardboard tube across the bottom, are perfect for hanging the traps. Use a 1-1/2" or 2" (~5 cm) fender washer for the main support. Drill two holes on either side of the central hole to mount eye-bolts. Mount the third eye-bolt will fit into the central hole. You will need two nuts for each eye-bolt and a 1/2" (~1.25 cm) washer that fits on the center eye-bolt.



Top left – Hanger. Top right – Trap top (Lee Rogers).

Bottom left – Trap bottom. Bottom right – Curtain (Lee Rogers).

The body of the trap is made up of three heavy wire rings. The galvanized wire that is used to strengthen the top of chain-link fencing works well. The wire comes in a coil and available at any hardware store. Cut three lengths of wire 6'2" (185 cm). Connect each piece into a loop using a #2 Chair lug (available in electrical supply store). This will result in a trap that is about 24" (60 cm) in

diameter. One ring is used for the top, one for the bottom, and one will be attached to the curtain as the weight to bring the curtain down quickly.

Attach ½” (1.25 cm) plastic hardware cloth to the perimeter of the top ring with J-clips (available at feed store, used for making rabbit cages). The hardware cloth provides a dark ceiling for the trap and the ½” squares allow any collected bees an escape path. Mark the outside edge of the top ring to divide the circumference into thirds. Set aside top until later.



Photo: Lee Rogers

Grey nylon screen door material (any hardware store) makes a good bottom floor. Lay the bottom ring on the screen door material and cut, leaving about 3” (7.5 cm) excess around the ring. Fold bits of the material over to make a series of darts around the base ring. Sew the material using a stretch stitch and trim the excess. Set aside bottom.

Cut a piece of soft nylon mesh material to be 19” x 72” (47.5 x 180 cm). Fold over about 1” (2.5 cm) on long edge and sew a pocket to be used to house a ¼” nylon tube. Sew the two short sides together to create a cylinder. Set aside curtain.

Connect the hanger assembly to the top unit. Locate the balance point of the top unit. It will not be in the exact center because the weight of the chair lug changes the balance point. Take the center eye-bolt and press open the loop to make a hook to hang the feeder on. Thread a nut all the way onto the eye-bolt, insert the eye-bolt into the center hole in the fender washer and through the closest hole to the balance point in the hardware cloth of the top unit. Put on the ½” washer on the eye-bolt and thread the second nut onto the eye-bolt. Install the other two eye-bolts by threading one nut as far as you can onto the eye-bolt. Insert the eye-bolt through the top and through the holes drilled in the fender washer on either side of the center hole. Tighten all nuts and attach wire clothes hanger. Hang up the assembled unit. It should hang pretty level, maybe slightly down on the side that has the chair lug. If the top tilts too much move the hanger assembly to a better position.

Attach three fishing rod tips to the top unit that will eventually house the drop strings. Note the three marks made on the outside edge of the top unit that divide the disk into three parts. Wrap a piece of construction wire (used in concrete work to tie rebar together, found in hardware stores) tightly around the galvanized wire of the top unit at each of the three points and cut so that there is about ½” of wire sticking out. Use JB Weld adhesive to glue the construction wire to the top unit, put extra adhesive around the ½” bit sticking out and slip the fishing rod tip over the wire. Set this aside until the next day to allow the adhesive to cure properly.





Top left – wire post for mounting rod tip. Top right – Rod tip glued in place (Lee Rogers).  
Bottom left – Adjustable loop with steel leader. Bottom right – Loop crimped closed and trimmed (Lee Rogers).

Attach the bottom unit to the top assembly using coated steel leader (fishing store, Cabela's, about 30 to 40 lb (~13-18 kg) test). Thread the steel leader through a #5 copper sleeve, around the top galvanized wire about ½" to the right of each rod tip, then back through the sleeve. Loop the leader back through the sleeve to ensure no slippage, adjust the fit and crimp the sleeve flat. Cut each steel leader to be 19 ½" (~49 cm) long.

Lay the bottom unit up against the top unit so that the chare lugs are on opposite sides (for balance). Mark the three spots on the bottom unit that correspond to the attach points of the steel leader at the top. Attach the leader to the bottom points. First thread the leader through a sleeve, into the spot marked on the bottom unit, back through the sleeve, loop around through the sleeve again to prevent slippage. Adjust each support line so that the distance between top unit and bottom is 17". DO NOT crimp the sleeve, leave it adjustable until the end.

Attach the nylon screen. First, loosen the chair lug on the third galvanized ring, cut off about 3" from the length of the wire and reconnect with the chair lug. This will allow the drop ring to fit nicely inside the support wires of the trap when operating. Lay the ring on the bottom unit and check the balance of the trap. Cut a piece of ¼" refrigerator tubing to fit the circumference of the trap, thread the ¼" tube through the small pocket sewn into the bottom of the nylon curtain and connect the loop with a 3" piece of 3/8" tubing. Pin the top edge of the curtain evenly around the top unit. Use the drop ring as a weight to hold the bottom of the curtain flat on the bottom of the trap while you are sewing the top edge of the curtain to the top unit of the trap. Use a locking stitch to hand sew the curtain to the top. Be mindful that the curtain stays even and uniform as it is sewn onto the top.

Mark the drop ring at the three points corresponding to the support lines. Attach a second length of steel leader about ½" to the right of each of the three support lines and crimp the sleeves at the top unit. Cut the length of these new leaders to be about 1" below the bottom trap unit. Thread the leader through a sleeve, around the galvanized drop ring, back through the sleeve, and loop back through the sleeve. Adjust the drop ring to be 14 ½" from the top unit. DO NOT crimp the sleeve until after the final adjustments.

Using a lock stitch, sew the drop ring to the curtain. Ensure the tubing in the bottom pocket of the curtain stays flat on the bottom trap unit. Now adjust the length of the leaders holding the drop ring to be 14" long and crimp the sleeves tight. Now adjust the leaders connecting the top to the bottom unit to be 15 ½" separation and crimp sleeves. With this configuration there will be a 1 ½" gap between the weighted drop ring and the bottom of the trap to ensure no bird is pinned by the ring.

Finally, place a 1" plastic ring over the close hanger hook, thread three lengths of braided nylon fishing line through the plastic ring, through the rod tip, and secure to the weighted drop ring. Once secure, tie the three ends of line together to set the length and then attach a swivel to the drop lines using a bowline knot. At this point you can attach a length of fishing line as a manual release or attach a remote trigger mechanism.

This trap is very light and fast but needs some stability to keep it from wiggling around when being operated. You can use a length of heavy plastic tubing filled with lead shot as a weight. Four lengths of 1/8" nylon line with a cord lock on the loop around the weighted ring, for adjusting height, and a small 'A' clip to attached to the trap. A bicycle wheel bag makes a nice trap carrier.

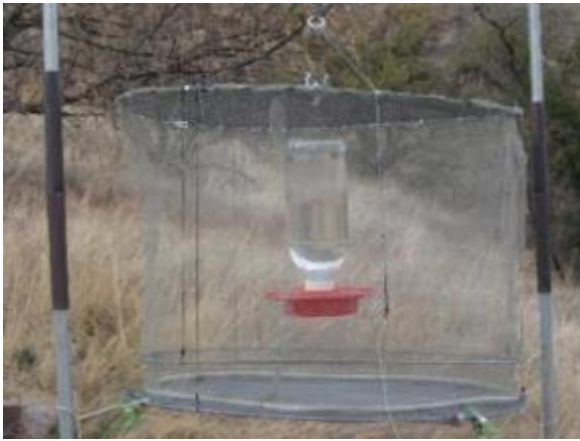

Photos: Lee Rogers

## C.5. Collapsible Dawkins/Mesh Netting Trap

### C.5.1 Materials list:

1. Two round metal "hoop style tomato cages" available at garden centers or plastic hula-hoops available at Dollar Stores and stores that sell children's toys. The 16-inch diameter works well. Cut one of the stakes that come with them and bend it to form an X in the center of the top of the trap.
2. Two 17" square pieces of 1/4" or 3/8" bird netting to cover the top and bottom of the trap.
3. One 20" X 55" piece of 1/4" or 3/8" bird netting for the side of the trap. This length will overlap about 5" and is used to place the feeder in the trap. Caution, do not use feeders with T perches, they will get hung up in the netting and are very difficult to take out.
4. Four pieces of cord about 14" long.
5. One large hook for hanging trap
6. Two small hooks for each end of the cord used to hang a feeder in the trap.
7. Spool of 20-30 lb (~9-13 kg) Monofilament fishing line or heavy duty thread to lace the netting to the hoops.

### C.5.2 Construction:

1. Use a piece of monofilament or thread to lace the 17" square pieces of mesh to top and bottom pieces. It may be easier if you use a couple of clothespins to hold the netting in place as you work with it. Overlap the netting about 1/2" in the middle of the piece to start and lace the monofilament through every 2 or 3 squares of mesh. Keep the line taut as you work your way around the hoop and tie it off securely when completed.
2. When the end pieces are finished it will be much easier to sew the sides to the trap if you attach the top and bottom to a 20" board.
3. Secure one corner of the 20" X 55" netting to the hoop, tying the monofilament line or thread through both parts.
4. Lace the side piece of netting around the top of the trap. It will overlap by about 5". Lace the bottom in the opposite direction, making sure the overlap is the same on the top and bottom. It needs to be perfectly straight so that it does not leave a gap when being used.
5. Tie three lengths of cord about 120 degrees apart to the top of the trap. Attach the cords to the large hook for hanging the trap. Be sure the knots are securely tightened so they will not come loose when being used.
6. Put the two small hooks that will go through the mesh on each end of the remaining piece of cord. Opposite the overlap, cut a small "door". The bottom of the cut should be 4" from the bottom and should be 5" by 3". Cut only the bottom and sides. Bend the cut material up and clip it to form the "door".

### C.5.3 Use:

These traps work best if hung away from trapping operations. Hang the trap and insert the feeder through the overlap. Remember, feeders without T style perches are much easier to use. Use the cord with hooks on both ends to hang the feeder inside the trap. Run the cord through the top of the trap at the X and attach it to one of the metal bars. Feeder ports should be at the level of the opening for hummingbirds to find their way into the trap. In use they will normally circle the trap at the port level until they find the opening. When they are frightened they usually go to the top looking for a way out. Birds should be removed through the door rather than the overlap on the side.



Cindy Cartwright photos.

## C.6. Mist Net (Russell) Trap

### C.6.1. Materials list

- 1 mist net: 6-m length, preferably 24 mm mesh
- 1 piece of mist net. Use a second net or a part of a net, 8-10 ft (about 2.4-3.0 m) long; (~3 m) nets may be available
- 10 poles: 10 poles, each about 5 ft (1.5 m); or four 7-ft (2.13-m) poles and two shorter poles (about 4-5 ft [1.2-1.5 m])
- 4 pole joiners (sleeves): each a 12-inch (30.5-cm) section of copper tubing, slightly crimped in center
- 2 sugar-water feeders
- 2 hooks made of stiff wire, to hold feeders on top of poles
- several 15-cm smooth sticks (plastic swizzle sticks work well)

### C.6.2. Tools needed

- Pole pounder or other means of fixing poles in the ground

### C.6.3. Instructions

Set up the net with three sides, the back just over 2 m long, and both sides a little less than 2 m long and converging slightly toward the front. Galvanized electrical EMT tubing with 0.5 inch (inside diameter) works well for the supporting poles, but any smooth pole that can be set upright will serve. Cover the top with the second net, running it from one side to the other and fastening it to the lower net in the corners to prevent escapes. Use small smooth sticks about 15 cm long to interlace the two nets at the top to seal openings where birds might escape. The lower edge of the net need not be close to the ground; hummingbirds tend to fly upward when trying to escape. The top should be within comfortable arm's reach of the person who will be removing the birds. Place two feeders about a meter above the ground on poles inside the trap; one about 0.5 m from the back and the other just inside the entrance.

## C.7. Modified Mist Net Trap

### C.7.1. Materials and tools

As for Russell trap.

### C.7.2. Instructions

Set up the sides as in Mist Net trap, but with the back of the trap facing the hummingbirds' preferred escape direction. Center the second net (roof net) horizontally on top of the other net; a portion of the top net should extend over the trap entrance and drop down about two feet. Place the remaining netting over the back of the trap. This provides a barrier at the top of the front of the trap where hummingbirds will encounter it when they try to exit by flying up. A few birds will fly down and out. The overlap on the back and sides needs to be secured; the top net may be placed over the corner poles.

## **C.8. Collapsible Netting Trap**

### **C.8.1 Materials list:**

8. Two round metal “hoop style tomato cages” available at garden centers. The 16-inch diameter works well. Cut one of the stakes that come with them and bend it to form an X in the center of the top of the trap.
9. Two 17” square pieces of 3/8” bird netting to cover the top and bottom of the trap.
10. One 20” X 55” piece of 3/8” bird netting for the side of the trap. This length will overlap about 5” and is used to place the feeder in the trap. Caution, do not use feeders with T perches, they will get hung up in the netting and are very difficult to take out.
11. Four pieces of cord about 14” long.
12. One large hook for hanging trap
13. Two small hooks for each end of the cord used to hang a feeder in the trap.
14. Spool of 20-30 lb (~9-13 kg) Monofilament fishing line to lace the netting to the hoops.

### **C.8.2 Construction:**

6. Use a piece of monofilament to lace the 17” square pieces of mesh to top and bottom pieces. It may be easier if you use a couple of clothespins to hold the netting in place as you work with it. Overlap the netting about 1/2” in the middle of the piece to start and lace the monofilament through every 2 or 3 squares of mesh. Keep the line taut as you work your way around the hoop and tie it off securely when completed.
7. When the end pieces are finished it will be much easier to sew the sides to the trap if you attach the top and bottom to a 20” board.
8. Secure one corner of the 20” X 55” netting to the hoop, tying the monofilament line through both parts.
9. Lace the side piece of netting around the top of the trap. It will overlap by about 5”. Lace the bottom in the opposite direction, making sure the overlap is the same on the top and bottom. It needs to be perfectly straight so that it does not leave a gap when being used.
10. Tie three lengths of cord about 120 degrees apart to the top of the trap. Attach the cords to the large hook for hanging the trap. Be sure the knots are securely tightened so they will not come loose when being used.
11. Put the two small hooks that will go through the mesh on each end of the remaining piece of cord. Opposite the overlap, cut a small “door”. The bottom of the cut should be 4” from the bottom and should be 5” by 3”. Cut only the bottom and sides. Bend the cut material up and clip it to form the “door”.

### **C.8.3 Use:**

Traps work best if hung away from trapping operations. Hang the trap and insert the feeder through the overlap. Remember, feeders without T style perches are much easier to use. Use the cord with hooks on both ends to hang the feeder inside the trap. Run the cord through the top of the trap at the X and attach it to one of the metal bars. Feeder ports should be at the level of the opening for hummingbirds to find their way into the trap. In use they will normally circle the trap at the port level until they find the opening. When they are frightened they usually go to the top looking for a way out. Birds should be removed through the door rather than the overlap on the side.

## **C.7. Bags, Holding**

### **C.7.1. Materials**

- netting
- soft nylon twine
- one cord lock (spring-loaded closure common on jacket drawstrings) for each bag
- bodkin or large safety pin

### **C.7.2. Directions for sewing net bags**

Finished bags are approximately 20 cm wide, 23 cm high. Durable fish net material can be ordered from Nichols Net & Twine Co., Inc., see Appendix B. For one bag, cut a piece of netting about 40 x 25 cm. Along one 40-cm side, fold the edge under 6 mm, and then again 19 mm, as with a hem. Stitch the hem. Fold the short edges together and stitch around the two open unhemmed sides to form a bag. A zigzag stitch lasts longer. Do not stitch across the openings to the hem. Measure and cut a 64-cm piece of nylon twine, sealing the ends with a flame as soon as it is cut. Attach a bodkin or a large safety pin to one end, and work the pin with attached twine through the hem. Thread the two ends of twine through the hole in the closure and tie them in a knot.

Option: to reinforce bottom seam of each bag and easily identify the bags if you use similar bags for larger birds, fold brightly colored seam tape over the bottom seam and sew with a zig-zag stitch.

### **C.7.3 Holding Bags from Lingerie Wash Bags**

Alternately, holding bags may be modified by fabric bags known as lingerie wash bags or mesh wash bags; these are sold in department stores. They are made of polyester mesh measuring 5x5 mm, and the wash bags themselves come in different sizes depending on brand, i.e., 11.25 x 15.25 in (29 x 39 cm), 15 x 18 in (38 x 46 cm), 18.5 x 23.5 in (47 x 60 cm), or in the case of the one

depicted here 16 x 20 in (40 x 50 cm) which yields six holding bags 6.5 x 6.5 in (16 x 16 cm). Wash bags of the other sizes can be employed using altered dimensions for whatever ultimate bag size one wants.

Referring to figure below, with the wash bag on a flat surface make Cut 1 with sharp scissors, then Cut 2, discarding the top portion of the wash bag with zipper. Then make Cuts 3 and 4.

From a 6-ft (183 cm) long piece of 1/2-in (1.3 cm) wide bias tape (sold in fabric shops) cut 11 pieces 6.5 in (16 cm) long. Starting with Bag 1 which retains its left and bottom sides from the original wash bag, fold the bias tape lengthwise along the right side so that half the tape is on the upper side, half on the lower side and sew using a zig-zag stitch to close the side, leaving open the top of the bag. Bag 2 requires bias tape on its right and left sides leaving open its top, and Bag 3 requires bias tape on its left side leaving open its top.

Bag 4 requires bias tape on its top and bottom sides leaving its right side open as a top. Bag 5 requires bias tape on three sides: left, bottom and right, leaving the top open; and Bag 6 requires bias tape on top and bottom leaving its left side open as a top.

The pull strings on the bags are shoe laces from sport shoes such as tennis shoes measuring 24 or 27 in (61 or 69 cm) in length. Start at one open corner of a bag and thread the shoe lace through every fourth or fifth mesh along the top until the entire top of the bag is threaded, then pass the two ends of the shoe laces through the cord lock tying together the two lace ends in a manner depicted in Figure F.

When necessary after use, the bags may be hand washed in a dishpan with warm water and a drop or two of mild detergent, thoroughly rinsed and dried. One bag may be used as the container for the other five bags.

Figure F. Holding Bag.

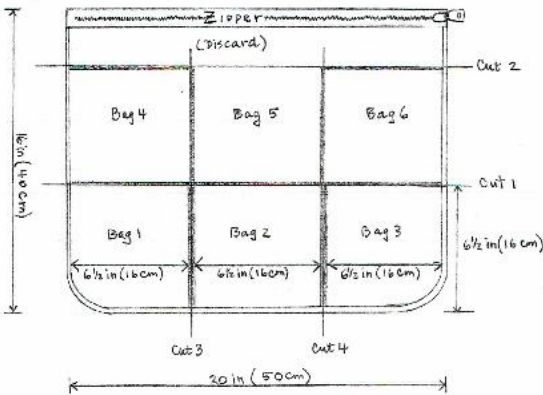

### **C.8. Cages, Holding**

Holding cages are suitable for short-term storing of a few hummingbirds awaiting processing. Do not use them unless someone watches them almost constantly to be sure all birds are feeding and in good condition. Usually birds confined in the small cages are not aggressive and all birds are able to feed.

These cages are light-weight wooden frames covered with netting. They should be about 40 to 46 cm on a side. Make the frame of 0.5- x 0.75-inch (1.3- x 1.9-cm) molding (or anything similar). The corners may be cut to fit together and secured by a screw or glue. Use any sort of durable fine transparent mesh cloth (obtainable at outdoor supply or fabric stores), wash with fabric softener, and fit and staple it to the wooden frame. One side must have an opening through which to transfer the hummingbirds. On this side, use two pieces of netting, each piece covering about two-thirds of the side and allowing for overlap in the center. The upper piece should overlap the lower one on the outside and their edges should be hemmed to resist wear. Secure the edges with clothespins when birds are in the cage. Make a small hole in the center of the top and suspend a feeder hung on a dowel placed across the top of the cage. Perches of thin branches can be inserted just prior to use and held in place by the pressure of the net sides. Birds can perch on the branches or cling to the soft net sides.

## **APPENDIX D. BANDING ASSOCIATIONS AND MEETINGS.**

Refer to Appendix A of the Banders' Study Guide for a list of associations and bird observatories. To be informed of various training opportunities as they arise, join a regional banding association, or monitor the "BIRDBAND" listserv group <http://www2004.lsoft.se/scripts/wl.exe?SL1=BIRDBAND&H=KSU.EDU>. Once you are a permitted hummingbird bander (Master or sub-permittee, consider joining the "HUMBAND" listserv, specifically for hummingbird banders' to discuss techniques and share ideas. Send a request to join along with your permit number, state/province where you are permitted to band FROM the email address you wish to use to post and receive messages from Humband. Send the request to [routledges@bellsouth.net](mailto:routledges@bellsouth.net) [orsusan.heath888@gmail.com](mailto:orsusan.heath888@gmail.com). You will receive an email to confirm your request.

## **APPENDIX E. LONG-TERM CARE AND REHABILITATION OF HUMMINGBIRDS**

Much of this section is for the benefit of avian rehabilitators who have had little experience with hummingbirds. Banders may not hold birds for longer than 24 hours without special permission.

### **E.1. Injured Birds**

In the case of long-term care due to a head injury, add a steroid such as Decadron to the sugar water feeding to keep the brain from swelling and to control shock. Place one small drop of Decadron in a feeder with 3 cc of sugar water twice daily for 2 days. Decrease the dosage by half on days three and four. Do not give Decadron on the fifth day.

If the bird has difficulty perching, restrict its movements. Cut a paper towel into four equal squares. Fold one square twice to form another smaller square, and cut a tiny triangular piece off its inside corner. When opened it is now a square with a small central hole. Place the bird's head through the hole and wrap the paper towel around its body. Secure the wrap with a paper clip, slipped up the back, or a piece of tape. Place the wrapped bird in a tiny cup, such as a small Dixie cup, or very small clay flower pot, so its head sticks up over the top. This confines the bird, helping to reduce stress and energy use. Place a feeder directly in front of the bird slightly below bill level so it has access to food at all times. Change the wrap several times each day as needed.

Wing injuries require care similar to head injuries. Confine the bird to cause no further injury. A broken wing can heal, depending on the severity and location, but requires at least 7 days and as many as 10 days without movement. After the wing has healed, place the bird in a cage about 30 cm square with plenty of perches so it can slowly regain strength. When it is healthy, move it to a cage about 60 x 90 x 60 cm or greater, until it is strong and flying well. Be aware that birds with wing injuries are difficult to rehabilitate and rarely survive.

A hummingbird cannot survive for long on sugar water alone. You must add protein if you keep it for more than a few days. For short-term, quick protein, you can dissolve dried tubifex worms (available at aquarium supply stores) in sugar water at the rate of one cube of worms to one cup sugar water. For birds held long term, protein in the form of fruit flies (*Drosophila*), is easily raised by putting a banana peel in a small open-mouthed jar. Place the jar in front of the hummingbird, and it will catch the insects as they hatch and fly. You can buy a fruit fly growing kit for minimal cost (see Appendix B. Foods, special). Nektar Plus, from the Nekton company (see Appendix B. Foods, special), is an expensive, but quality, proven, long-term food. It contains all the nutrients hummingbirds need. Feed six parts water to one part powder for birds in rehabilitation, and still add fruit flies to their diet.

### **E.2. Long-term Care**

At the Arizona-Sonora Desert Museum in Tucson, Arizona, captive hummingbirds are healthy and long-lived. They have three sources of food; the primary source is Nektar-Plus, a commercial food composed of carbohydrates, protein, fats, vitamins, minerals, and trace elements. They also have a variety of nectar-rich plants, and an ample supply of *Drosophila*. During molting

and nesting, the birds require increasing numbers of the latter.

In addition to the required foods, hummingbirds housed outdoors need bushes and trees for secure roost areas. They should have sufficient shade in the summer, and cover and warmth in the winter. A heat lamp may be used to provide warmth, but the birds must have the choice of sitting in front of the lamp or not. In harsh climates hummingbirds should not be housed outdoors in winter. They bathe regularly and should be given daily opportunities to do so. Hose vegetation lightly or use a spray bottle. Some birds will bathe on the wet leaves of the vegetation, but others will let you gently spray them with the bottle. The bathing helps keep feathers conditioned. All holding areas, indoors or outside, should allow ample flying space. If housing more than one bird, provide ample room as they may be aggressive and perhaps territorial. Females get along together better than males. Always provide more feeders than birds; a good rule of thumb is two feeders per bird. Watch for any problems among the birds; a bird being chased by others and not being allowed to feed can perish quickly. If you see such behavior, remove the harassed bird. Captive hummingbirds provided with their basic needs should do well, but be aware of possible aggression if two or more birds are housed together. Do not assume they will get along well together; they need the opportunity to set up territories. Your good observation skills will help avoid problems.

## **APPENDIX F. SKILLS AND KNOWLEDGE EXPECTED OF HUMMINGBIRD BANDERS**

Following is a checklist of the skills and knowledge you should have before requesting a permit to band hummingbirds. It is based upon The Bander's Report Card in the Banders' Study Guide and has been amended to include categories unique to hummingbirds. Because hummingbird banders must be familiar with the handling and care of birds other than hummingbirds that may enter their traps or nets, the checklist includes skills that apply to other birds also.

Not all categories need to be checked (initialed) for a banding permit. Some categories are fundamental, however, and need to be assessed for all prospective banders. These are identified by an asterisk. Items with double asterisks are essential elements for prospective Master Permittees.

### **BACKGROUND MATERIAL**

- \* **Understand the ethics of banding birds**
- \* **Understand how banding fits into scientific studies**

### **CHECKLIST OF PRACTICAL SKILLS**

#### **PROCESSING**

##### **Identification and handling**

- \* Recognize all target species. Know the circumstances under which a bird should be released unbanded. Know how to report hybrids.
- \* Appreciate the importance of minimizing handling time while not compromising safety
- \* Use the bander's grip on a variety of species
- \* Use the photographer's grip safely
- \* Use the "Finger-tip Holds" safely
- \* Transfer a bird from hand to hand safely
- \* Handle a variety of awkward species
- \* Release a variety of species correctly
- \* Effectively deal with escaped birds in an enclosed space
- \* Remove hummingbirds from traps (and nets, if used) without jeopardizing their safety
- \* Handle and transfer hummingbirds correctly
- \* Identify which grips are not acceptable for hummingbirds and rationale.
- \* Identify concerns associated with banders' grip and hummingbirds
- \* Use the fingertip grip safely

##### **Banding**

- \* Strip and prepare bands of the correct sizes
- \* Make bands without sharp edges and abut them squarely
- \* Place bands on hummingbirds without trauma to them
- \* Close bands properly
- \* Process birds within reasonable time after capture, to reduce stress
- \* Read band numbers correctly
- \* Recognize when and how to correct an improperly applied band
- \* Know when and how to remove a band safely

##### **Holding and carrying birds**

- \* Use the appropriate method to temporarily hold hummingbirds
- \* Place birds in bags and carry and hang them correctly
- \* Recommend when bags or boxes need cleaning

### **Field data collection**

- \* Record data clearly, legibly, and accurately on field sheets or in computer data base
- \* Recognize and document rarities or unusual birds
- \* Maintain complete and accurate daily logs

### **Biometrics**

- \* Use and accurately read measuring devices (rules, balances, calipers, dividers)
- \* Understand how to correctly calibrate measuring devices
- \* Correctly, consistently, and accurately measure various anatomical features
- \* Assess simple wing formulae
- \* Assess and record molt accurately on a molt card
- \* Accurately score fat deposits

### **Ageing and sexing**

- \* Correctly use guides for ageing and sexing immature hummingbirds
- \* Correctly use other characteristics for age determination
- \* Understand and assign correct age codes

### **SPECIAL AUTHORIZATION FOR MIST NETTING**

#### **Erecting, opening, and closing nets**

- Choose an appropriate netting or trapping site and appropriate net
- \* Correctly set up nets unaided, including traps utilizing nets
- Furl and unfurl nets properly
- Take in and store nets and associated equipment properly

#### **Operation and extraction**

- Judge how many nets to use safely and check them frequently and carefully
- Demonstrate an astute, accommodating approach to extraction
- \* Extract hummingbirds (and any other birds captured) quickly and safely
- Deal proficiently with tricky situations
- Recognize and maintain nets that are in poor condition

#### **TRAPS**

- \* Know a range of traps and their target species
- \* Operate traps properly and safely
- \* Identify and understand the concerns & cautions associated with each type of trap

#### **ETHICS AND INJURIES**

- \* Know and practice the Bander's Code of Ethics
- \* Show excellent awareness of injury and shock prevention
- \* Show familiarity with shock and the most common injuries and their causes
- \* Demonstrate ability to treat minor injuries and shock
- \* Recognize the necessity for euthanasia, and be able to demonstrate appropriately
- \* Assess whether a specimen is worth preserving
- \* Record details of any injury or casualty
- \* Demonstrate appropriate techniques for feeding hummingbirds held in the hand
- \* Recognize signs of stress and promptly treat them

#### **HEALTH AND SAFETY OF BANDERS**

- \* Demonstrate a responsible attitude towards potential injuries from birds
- \* Demonstrate a responsible attitude towards physical hazards in the banding area

#### **DATA MANAGEMENT**

- \*\* Proof and correct banding sheets
- \*\* Complete data submissions via Bandit® properly without assistance
- \*\* Handle other paperwork correctly and promptly

#### **PUBLIC RELATIONS**

- \* Communicate effectively with the public about banding
- \* Communicate effectively using banding data (reports, articles etc.)

#### **OTHER SPECIAL AUTHORIZATIONS**

Demonstrate proficiency in any special authorizations (specify):

#### **FINAL ASSESSMENT**

- \* Ethics
- \* Processing
- \* Special Authorization for Mist Netting



- \* Traps
- \* Injuries to Birds
- \* Health and Safety of Banders
- \* Record Keeping
- \* Public Relations

## **APPENDIX G. AN INSTRUCTOR'S GUIDE TO TRAINING HUMMINGBIRD BANDERS**

To collect accurate and reproducible banding data, properly trained people versed in correct and acceptable banding techniques are needed. This assures quality data and also that the birds receive proper and respectful care they rightly deserve during the banding process. See the NABC's *The Instructor's Guide to Training Passerine Bird Banders in North America* for general guidelines.

### **G.1. Training and Conditions Needed for Training Sessions**

#### **G.1.1. Trainers**

Trainers should be hummingbird banders with an in-depth knowledge of hummingbird banding and sufficient experience to be adept at handling the birds and skilled in the techniques used to band them. They also must have an outgoing presence, with an ability to teach, explain, answer questions, and be able to give honest feedback to trainees on how well they are doing.

#### **G.1.2. Duration of training**

The duration depends on the capabilities of trainees; their individual time commitments, and the availability of adequate numbers of birds. Training may take anywhere from a few days to several months or even years, depending on the specific situation.

#### **G.1.3. Location of training site**

The site should assure enough hummingbirds for trainees to handle an adequate number to be decided on by the trainers. This number should be adequate to allow the trainee to handle the minimum number of hummingbirds designated by the BBO/BBL and any additional numbers deemed appropriate by the trainers.

### **G.2. Who Should be Accepted and Requirements Needed for Trainee**

Anyone who wishes to band hummingbirds should have no physical limitations that might prevent their careful handling, as the birds' welfare must always be the primary concern. Good closeup vision is necessary. If you cannot see tiny, 3 gram birds clearly using glasses or a magnifying visor, you should not handle them because you could injure them. You also need infinite patience, steady hands, and manual dexterity.

Training and experience banding passerines provides a basic understanding of data collection, holding birds in hand and in cages, using mist nets, handling stressed birds, and how to avoid stressing them. Although none of these is an absolute prerequisite, they provide experience and may increase the probability of your becoming a successful hummingbird bander.

### **G.3. Steps in How to Train**

#### **G.3.1. Observation of banding**

Trainees should first observe hummingbird banding for a specified period of time. You need to see more than just someone holding and talking about hummingbirds, perhaps a whole morning of a busy banding session. The trainer should assess the visual ability and manual dexterity of a potential trainee before proceeding.

#### **G.3.2. Holding birds; instructions for extracting birds from traps and nets**

Trainees should first become comfortable holding hummingbirds. Several ways of holding should be explained, and careful instruction given on how to remove all birds from mist nets and traps. How bands are formed and readied for use needs to be explained in detail.

#### **G.3.3. Background information**

Include brief background information on hummingbird life cycle, molt, breeding, etc. Explain data sheet and information collection. Trainee to start recording data.

#### **G.3.4. Initial tasks**

Since learning to band one bird from start to finish takes a long time, and probably would be too stressful for individual hummingbirds, trainees could do a few steps and the trainer finish the bird reasonably quickly. Gradually the number of banding steps the trainees undertake should be increased until they have completed the whole procedure.

### G.3.5. Assess trainee's capabilities

The trainer must continually check on the trainee's capabilities, then either give an organized mid-session assessment or personally discuss how well the trainee is doing. Remember that the trainee may never have held a bird previously and is probably very nervous. Praise when something is well done, then any later criticism will be accepted more readily.

### G.3.6. Trainer's judgment

At the beginning, the trainees should be told that if, at any time during training, the trainer finds them to be ill-suited to band hummingbirds, they will be informed that they will need to make serious changes or be disqualified.

#### An example training process by a Trainer

1. Trainee watches throughout process and listens to explanations
2. Trainer completely process birds and trainee practices various grips before releasing. Also discuss signs of stress at same time.
3. Trainer completely process then trainee starts practicing various measurements. Bird is released after reasonable time and trainee practices on another bird. This continues until the trainee can complete all the measurements satisfactorily.
4. Once trainee is obtaining accurate measurements (within 1 mm) consistently, and they can complete all measurements in less than 3 minutes, the Trainer bands and the trainee processes (occasionally Trainer will take a bird when they are done and recheck their measurements to ensure they are remaining accurate)
5. Trainee starts applying bands and processing – Trainer double check bands for fit/good closure and if trainee takes too long, Trainer will finish processing to speed bird's release
6. Eventually Trainee is doing everything with verbal encouragement and supervision. Trainer will still take birds from time to time to double check measurements for accuracy and check bands for fit/closure.

### G.3.7. Written test and evaluation

A written test and a practical may be given at the end of the training session, and perhaps a final assessment in case areas need improvement. The knowledge/skill requirements for a hummingbird bander must include the ability to properly produce bands that can be safely used on the birds. Hence, hummingbird banders must be able to demonstrate the ability to make bands before the BBL will add hummingbird authorization to a banding permit.

## APPENDIX H. A KEY TO WESTERN HUMMINGBIRDS

### H.1. A Key to Female and Hatching-year Western Hummingbirds

This key is designed to facilitate the identification of adult female and hatching-year hummingbirds in the western United States. It is untested and your comments will be appreciated. Adult male hummingbirds, characterized by a full gorget of iridescent feathers (and/or sometimes an iridescent crown) are not included and should be identified from a field guide. Refer to Pyle (1997) to age and sex females and juveniles of Blue-throated, Magnificent, and Lucifer hummingbirds.

The abbreviation "p" is used for primary and "r" is used for rectrix. Therefore, p10 refers to the outermost primary and r1 refers to the inner (central) tail feather. First determine if bill corrugations (Fig. 20 below, and Fig. 36, section 8) are present, then measure the wing chord (Fig. 32, section 8), tail (Fig. 33 section 8), exposed culmen (Fig. 19 below, and Fig. 34 and 35, section 8), and the width of r5 (Fig. 29, below). The wing chord is the length to nearest millimeter (mm) of the unflattened wing from the anterior edge of the wrist (bend) to the tip of p10 (the longest). If p10 is molting or missing, this measurement is worthless. Measure the tail to the nearest millimeter, from the skin between the two central rectrices to the tip of the longest rectrix. If r5 is missing, the tail measurement will not be useful. Using calipers, measure the top of the culmen to the nearest 0.1 mm, from the tip of the bill to the edge of the feathers. Additionally, on some birds you also must measure (to nearest millimeter) the white at the tip of r3; measure the extent of white along the rachis (length; Fig. 30, below) and the maximum width of the white (Fig. 31, below). When the key calls for an "area" measurement, this is the length times the width of the white in r3. Measurements of very worn feathers may be misleading and not useful in the key. "Grooves" as used in this key refer to bill corrugations or corrugations, but ignore any in the nostril area. The key does not attempt to identify SY hummingbirds because the methods are relatively untested.

Not every bird will "key out" satisfactorily to species, age, and sex. When a bird does not match the key, you may need to make decisions based on several characters and ignore the mismatched character. Consult references, especially Baltosser (1987), Pyle (1997), and Stiles (1972); Table 2, page 135 in Pyle may be helpful. Rarely, perhaps in fewer than 1% of immature or adult female birds, you will not be able to identify the species; report those in doubt as UNHU, Species code 4409, or do not band them. If more than 1% of the immature birds and adult females that you encounter cannot be identified, you should reassess your identification skills.

- 1a. Bird has complete iridescent gorget and/or crown, and no grooves. The bird is an AHY male, unless it is an adult Violet-crowned Hummingbird in which the sexes are indistinguishable. Use a field guide to identify adult males.
- 1b. Gorget or crown not completely iridescent. Females or HY. ....2

2a.	Wing >68 mm; tail >41 mm.....	3
2b.	Wing <68 mm; tail <41 mm. ....	4
3a.	Forehead feathers do not cover nares. Culmen usually <24.3 mm. <b>Blue-throated BLUH.</b> See Pyle (1997) for age, sex characters.	
3b.	Forehead feathers cover nares. Culmen >24.3 mm.  <b>Magnificent MAHU.</b> See Pyle (1997) for age, sex characters.	
4a.	Outer web of p1-p6 narrower than p7-p10 (“primaries unequal,” Fig. 22). <i>Archilochus</i> .....	5
4b.	Outer web of p1-p6 approximately equal in width to p7-p10 (Fig. 23). ....	8
5a.	Width of inner web of p10 (measured at point on rachis 5 mm from its tip) <2.5 mm (Figs. 30 and 31, below). This may be a <b>Ruby-throated RTHU</b> , a species rarely recorded in the west. If you are in the west and think that you may have a RTHU, check both Baltosser (1987) and Pyle (1997) carefully. Photograph the bird, including closeups of the tips of the primaries (Fig. 36).	
5b.	Width of inner web of p10 within 5 mm of tip >3.0 mm. <b>Black-chinned BCHU</b> .....	6
6a.	Bill smooth. Tip of r5 similar to Figure 25A. <b>AHY Female Black-chinned BCHU.</b>	
6b.	Grooves present on sides of bill.....	7
7a.	Tip of r5 pointed and/or emarginate (Fig. 25A or B), and tip of p6 pointed (Fig. 24). Little white at tip of r3 (length times width <10; (Figs. 28, 29). <b>HY Male Black-chinned BCHU.</b>	
7b.	Tip of r5 rounded (Fig. 25C) and tip of p6 rounded, not emarginate (Fig. 24). Considerable white at tip of r3 (length times width >10). <b>HY Female Black-chinned BCHU.</b>	
8a.	Bill decurved, without red; culmen >½ wing length. <b>Lucifer LUHU.</b> See Pyle (1997) to sex and age.	
8b.	Bill straight, black, or with red; culmen <½ wing length. ....	9
9a.	Bill red or reddish at base; culmen >18.5 mm. <b>Broad-billed BBLH</b> .....	10
	Note: White-eared improbable, but if culmen <18.5, refer to Pyle (1997).	
9b.	Bill without red. ....	12
10a.	Bill smooth. No iridescent blue gorget feathers. r5 usually with much white (Fig. 32). <b>AHY Female Broad-billed BBLH</b> until 20 August; later, designate them age <b>U Female BBLH</b> . Many BBLH (of both sexes) complete the prebasic molt before they migrate, contrary to Pyle (1997), and have lost bill grooves by the end of August. Pyle suggests that if the red of lower mandible blends gradually into the dark tip (instead of having a sharp break between red and black), it is probably HY. This character has not been adequately tested. No known AHY females in Arizona have had any blue in the gorget.	
10b.	Bill with grooves; with or without some iridescent blue feathers in gorget; r5 with little or no white. ....	11
11a.	Iridescent blue feathers in gorget; tip of r5 usually with small amount of white, as in Figure 32. <b>HY Male Broad-billed BBLH</b> Smooth-billed birds with incomplete blue gorgets are <b>HY Male</b> . The significance of the amount of white in the tip of r5 is undetermined, contrary to Pyle (1997).	
11b.	No blue feathers in gorget and tip of r5 usually with considerable white at tip (Fig. 32).  <b>HY Female Broad-billed BBLH</b>	
12a.	Tiny: culmen <16.5 mm, wing <44 mm; no rufous dorsally (but there may be rufous in the tail), r1 is expanded near the tip (spatulate; Fig. 33) and dusky or black at tip. <b>Calliope CAHU</b> .....	13
12b.	Not tiny as in 12a, and without spatulate r1; r1 may or may not be black or dusky at tip. ....	15

13a.	Culmen without grooves. Head and neck feathers not tinged buffy. Rufous may or may not be present in rectrices. A few or no small iridescent rose feathers may be present in gorget. <b>AHY Female Calliope CAHU</b>	
13b.	Culmen with grooves, head and neck feathers tinged with buffy.	14
14a.	Some rufous present along edges of r1. <b>HY Male Calliope CAHU</b>	
14b.	No rufous in r1. <b>HY Female Calliope CAHU</b>	
15a.	Without rufous in tail. <i>Calypte</i> .....	16
15b.	Rufous in tail <i>Selasphorus</i> .....	21
16a.	Width of r5 <4.3 mm, wing <46.2 mm. Costa's .....	17
16b.	Width of r5 >4.3 mm, wing >46.5 mm. Anna's .....	19
17a.	Bill smooth. Occasionally a few small iridescent purple feathers in throat. <b>AHY Female Costa's COHU</b> .....	
17b.	Bill with grooves. <b>HY COHU</b> .....	18
18a.	Black of r5 does not extend as a point into white at tip (Fig. 26). Area (length times width) (Figs. 30, 31) of white in r3 >10. <b>HY Female Costa's COHU</b>	
18b.	Black of r5 extends as a point into white at tip (Fig. 26). Area (length times width) of white at tip of r3 <8. There may be several purple feathers in gorget, often including ones on the sides (the "ears" of the gorget). <b>HY Male Costa's COHU</b>	
19a.	Bill smooth; usually 10-20 iridescent red feathers in center of grayish green throat. Occasionally a few reddish feathers in crown. <b>AHY Female Anna's ANHU</b> Caution: If there are few red feathers in throat, the bird could be <b>HY F</b> . In southern Arizona, ANHU begin to nest in late autumn, thus young birds may have lost their grooves by summer. See Baltosser (1987) and Pyle (1997).	
19b.	Bill with grooves. <b>HY Anna's ANHU</b> .....	20
20a.	Black of r5 does not extend as a point into white at tip (Fig. 26). There may be a few (up to 5) pinkish red feathers in the gorget. <b>HY Female Anna's ANHU</b>	
20b.	Black of r5 extends as a point into white at tip (Fig. 26). There may be several pinkish red feathers in the gorget or gorget and crown. <b>HY Male Anna's ANHU</b> Note: Anna's begin to nest in late autumn in southern Arizona. Young males that are 6-7 months old may have lost their bill grooves and perhaps even molted their rectrices (the tip of r5 will be all black). But these young males lack a complete gorget and the crown will be incompletely red. Identify these individuals as age <b>HY</b> or <b>U</b> ; identifying birds as <b>SY</b> is questionable.	
21a.	Wing >46.3 mm <b>Broad-tailed</b> .....	22
21b.	Wing <46.6 mm <b>Rufous or Allen's</b> .....	24
	Note: If wing >46.3 and <46.6 mm, see Stiles (1972) or Pyle (1997); the bird could be a Broad-tailed or Rufous.	
22a.	Culmen without grooves; width of r5 4.3-5.4 mm. Usually no, a few or many magenta-reddish feathers in gorget. r1 is green, usually without dark tip and without rufous on sides near base. NOTE: some banders have documented AHY/F BTLH with as many as 18 small magenta gorget feathers <b>AHY Female Broad-tailed BTLH</b>	

22b.	Culmen with grooves; width of r5 <4.3 mm. A few adult male-type feathers may or may not be present in gorget. r1 may or may not have some rufous, white tip of r3 is small and somewhat pointed .....	23
23a.	p10 narrow and curved (Figs. 34A, B); no, or only a few, iridescent adult male-type magenta gorget feathers; r1 green without a black tip and with some rufous on sides at base, r3 white tip small, narrower than that of HY/F (<~ 3 mm and somewhat pointed). <b>HY Male Broad-tailed BTLH</b>	
23b.	p10 rather broad, blunt (Figs. 34C, D); no reddish feathers in gorget; r1 without black tip (although margins near tip may have darker sheen than rest of feather). The edges of the base of r1 do not appear rufous; r2 may have no rufous or only a trace on basal edges, sometimes with a small white tip, wider than that of HY/M (>~ 4 mm) and somewhat rounded. <b>HY Female Broad-tailed BTLH</b>	
24a.	Proximal portion of r1 mostly rufous (Fig. 35).....	25
24b.	Proximal portion of r1 with little (<45%) or no rufous.....	27
25a.	Culmen with grooves. <b>HY Male Rufous or Allen's</b> .....	26
25b.	Culmen without grooves. <b>AHY F Rufous or Allen's</b> (few individuals will fit into this category) .....	28
26a.	Width of r5 <2.7 mm. r2 not emarginated or only slightly emarginated. <b>HY Male Allen's ALHU</b>	
26b.	Width of r5 >2.6 mm. r2 slightly or moderately emarginated. <b>HY Male Rufous RUHU</b>	
27a.	Culmen with grooves. <b>HY Female Allen's or Rufous</b> .....	28
27b.	Culmen without grooves, scattered red gorget feathers. <b>AHY Female Allen's or Rufous</b> .....	29
28a.	Width of r5 <3.3 mm, width of r1 <7.8 mm. r2 not emarginated or only slightly emarginated. <b>HY Female Allen's ALHU</b>	
28b.	Width of r5 >3.3 mm, width of r1 >8.2 mm. r2 slightly or moderately emarginated; very few (1-2) or 0 red gorget feathers on a light throat <b>HY Female Rufous RUHU</b>	
29a.	Width of r5 <2.8 mm; width of r1 <7.6 mm. r2 not emarginated or only slightly emarginated. <b>AHY Female Allen's ALHU</b>	
29b.	Width of r5 >2.7 mm, width of r1 >7.7 mm. r2 slightly or moderately emarginated. <b>AHY Female Rufous RUHU</b>	

Users of this key may find the following references useful.

**Baltosser, W.H. 1987.** Age, species, and sex determination of four North American hummingbirds. *N. Amer. Bird Bander* 12:151-166.

**Baltosser, W.H. 1994.** Age and sex determination in the Calliope Hummingbird. *Western Birds* 25:104-109.

**McKenzie, P.M. and M.B. Robbins. 1999.** Identification of adult male Rufous and Allen's hummingbirds, with specific comments on dorsal coloration. *Western Birds* 30:86-93.

**Pyle, P. 1997.** *Identification Guide to North American Passerines*. Part I. Slate Creek Press, Bolinas, CA.

**Pyle, P., S.G. Howell, and G.M. Yanega. 1997.** Molt, retained flight feathers and age in North American hummingbirds. *In*: R. W. Dickerman, compiler. *The era of Allan R. Phillips: a Festschrift*. Albuquerque, NM.

**Stiles, F. G. 1972.** Age and sex determination in Rufous and Allen hummingbirds. *Condor* 74:25-32.

**Yanega, G.M., P. Pyle, and G.R. Geupel. 1997.** The timing and reliability of bill corrugations for ageing hummingbirds. *Western Birds* 28:13-18.

Figure 19. Measuring the exposed culmen. The recommended method: the “over and under” technique using the smaller set of “jaws”. This technique avoids touching the tip of the beak and any tongue that may be sticking out the bill tip (photo Lee Rogers).

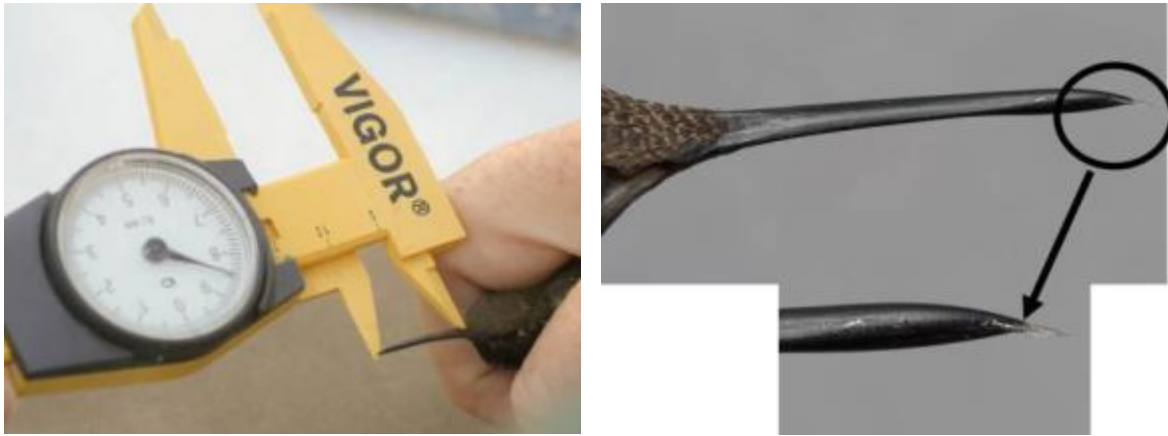

Figure 20. (A) Corrugations on the bill of a very young hummingbird. (B) Corrugations at the base of the culmen of an adult hummingbird; these markings are not useful in determining the age of the bird.

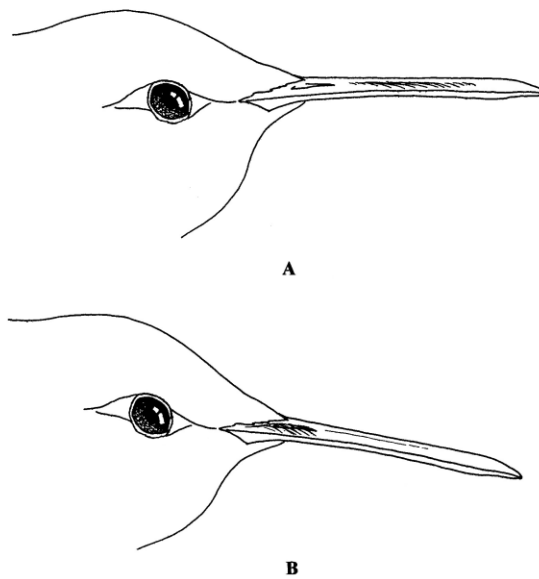

Figure 22. Outer web of inner primaries (p1-6) narrower than that of outer primaries (p7-10). *Archilochus*.

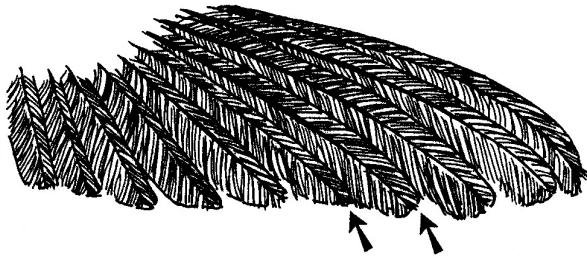

Figure 23. Outer web of all primaries approximately equal in width. *Calypte*.



Figure 24. Variation in the tip of p6 in *A. alexandri*.

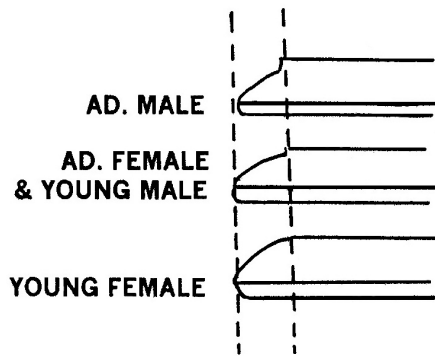

Figure 25. Shape of r5 in *Archilochus alexandri*. (A, B) tip is pointed and/or emarginated in adult female and young male; (C) tip is rounded and not emarginated in young female.

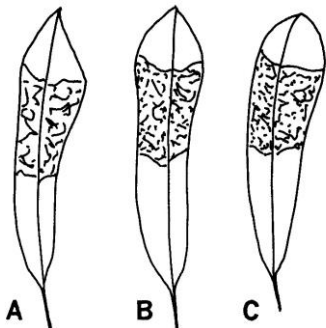

Figure 26. Variation in the pattern of white at the tip of r5 in *Calypte* females and young males (from Pyle 1997).

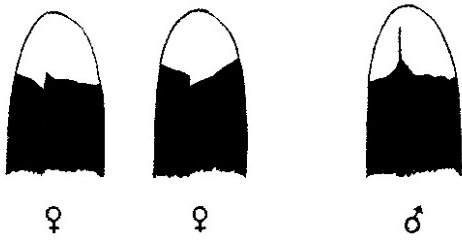

Figure 27. Maximum width of r5 (after Baltosser 1987) - measurement is taken with calipers at the widest part of the distal feather.

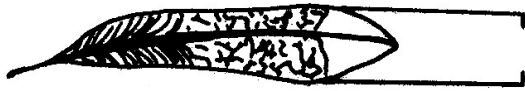

Figure 28. Length of white in r3, measured along the rachis (after Baltosser 1987).

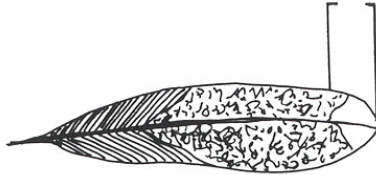

Figure 29. Maximum width of white at tip of r3 (after Baltosser 1987).

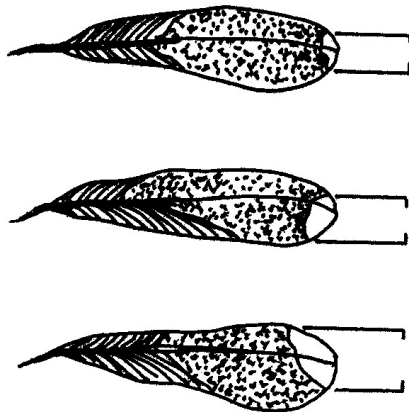



Figure 30. Measurement of width of inner web of p10. Maximum width of inner web of 10<sup>th</sup> primary (arrows) within 5 mm of tip, as measured along rachis (after Baltosser 1987).

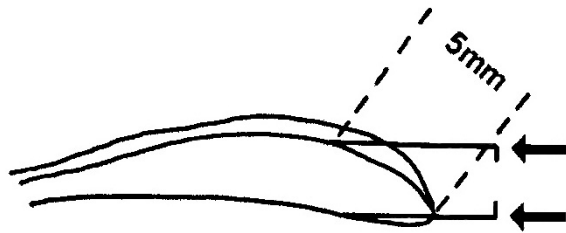

Figure 31. Shape of p10 in (A) *Archilochus alexandri* and (B) *A. colubris* (after Baltosser 1987).

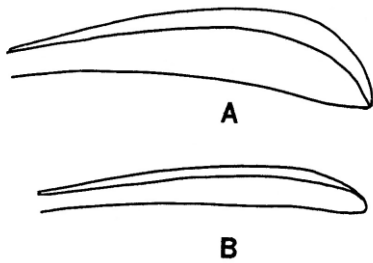

Figure 32. The amount of white in r5 in Broad-billed Hummingbirds, by age and sex (from Pyle 1997).

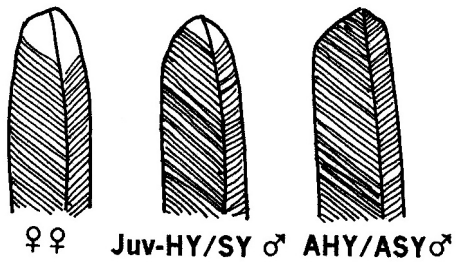

Figure 33. Diagnostic size and shape of r1 in the Calliope Hummingbird (sexes similar) compared to the size and shape of r1 in other, potentially confusing, hummingbird species (females only). (A) Ruby-throated (*Archilochus colubris*); (B) Black-chinned (*A. alexandri*); (C) Anna's (*Calypte anna*); (D) Costa's (*C. costae*); (E) Calliope (*Stellula calliope*); (F) Bumblebee (*Atthis heloisa*); (G) Broad-tailed (*Selasphorus platycercus*); and (H) Rufous (*S. rufus*) and Allen's (*S. asain*) (from Baltosser 1994).

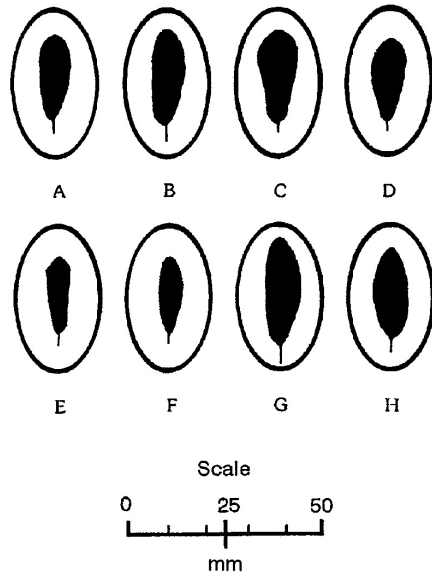

Figure 34. Variation in the width and shape of outer primary in Broad-tailed Hummingbirds. A and B are typical of HY males; C and D are typical of HY females (from Pyle 1997).

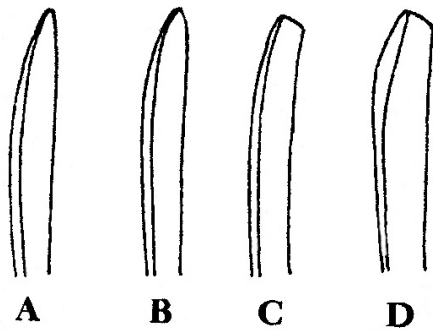

Figure 35. Shape and pattern of r1 in female and young Rufous and Allen's hummingbirds. The light stippling indicates rufous coloration and the dark stippling indicates green (from Pyle 1997).

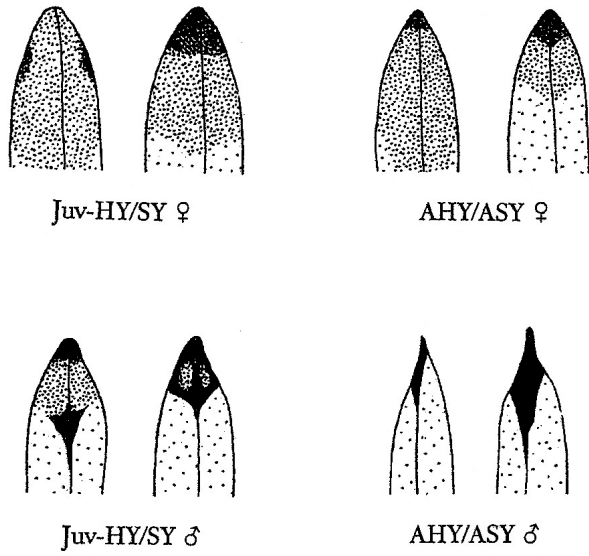

Figure. 36. Comparison of p6 in immature male and female RTHU



## APPENDIX I. THE NORTH AMERICAN BANDING COUNCIL

The North American Banding Council (NABC), incorporated in 1998, is a nonprofit group encompassing bird research organizations whose members use bird banding as a tool in ornithological research, conservation, and management ([www.facebook.com/NorthAmericanBandingCouncil](http://www.facebook.com/NorthAmericanBandingCouncil)). The mission of the NABC is to promote sound and ethical bird-banding practices and techniques. To accomplish this, the NABC has developed educational and training materials, including manuals on general banding techniques as well as technique manuals for specialized taxonomic groups accompanied by a three-level certification process (Assistant, Bander, and Trainer). Skill levels of banders will be increased by the preparation and dissemination of standardized training and study materials and the establishment of standards of competence and ethics for banders and trainers.

The immediate objectives are:

- (1) to develop a certification and evaluation program by setting standards for experience, knowledge, and skills that must be attained at each level (Assistant, Bander, and Trainer);
- (2) to produce and update training materials such as manuals and videos;
- (3) to identify and certify an initial pool of trainers; and
- (4) to encourage cooperative efforts in the use of banding in the study and conservation of North American birds.

The NABC consists of 18 to 20 voting members, including one representative that can be appointed by each of the following organizations: American Ornithologists' Society, Association of Field Ornithologists, Colonial Waterbird Society, Eastern Bird Banding Association, Inland Bird Banding Association, Ontario Bird Banding Association, The Pacific Seabird Group, Raptor Research Foundation, Society of Canadian Ornithologists, Western Bird Banding Association, Western Hemisphere Shorebird Reserve Network, and Wilson Ornithological Society; and two representatives appointed by the International Association of Fish and Wildlife Agencies (one from Canada and one from the United States). Other groups have been invited to become affiliated. The NABC also designates from four to six additional at-large members. The directors of the Canadian (BBO) and U. S. Bird Banding (BBL) Offices are nonvoting members of the NABC.

## APPENDIX J. OPTIONAL HUMMINGBIRD CHARACTERISTICS

Below is an optional list of fields and their length for coding hummingbird characteristics on forms; asterisked (\*) items are required when submitting banding data to the banding offices. This list may be of value in some research contexts.

Field (3 characters)	Explanation
CODE (1).	-- 1 indicates new bird, 2=recap, 0=released unbanded
TIME (3).	-- Time of capture; rounded downward to ten min; e.g., if the time is 9:18 am, enter 091
*BAND (6).	-- Band number; a letter and five numerals
WING (2).	-- Wing measurement to nearest millimeter
TAIL (2).	-- Tail measurement to nearest millimeter
CULMEN (4).	-- Culmen measurement to nearest 0.1 mm (or rounded to the nearest millimeter if a rule is used)
GROOVES (1).	-- y (yes) is entered if bill corrugations are conspicuous, s (slight, for a few grooves not near the base), n (no, for no grooves; ignore slight corrugations at bill base)
GORCOLOR (1).	-- Indicates color of metallic gorget feathers: o = orange (Rufous, Allen's), r = red (Anna's, Calliope, Broad-tailed, Ruby-throat), v = violet (Black-chinned), p = purple (Costa's, Lucifer), b = blue (Broad-billed, Blue-throated), w = white (Violet-crowned), you may add codes for other species
GORFCOUNT (3).	-- Count of metallic feathers if fewer than 15 or an estimate of the percentage of full gorget present. E.g., a male with half of its gorget feathers present would = 50. A full male gorget would be recorded as 100.
HEADFCOUNT (3).	-- If the species has metallic crown feathers, counted as for GORFCOUNT
VENTRAL (1).	-- Numeric characters are used if molt is evident in any of the ventral feather tracts exposed when the feathers are gently parted by blowing upon the length of the underside of the bird. The number of pin (sheathed) feathers is recorded as 1 = a few (<6 sheathed feathers); 2 = moderate molt; 3 = many sheathed feathers.

If no molt is seen, wear data is entered as:

F = fresh (no wear; the feather edges are intact);

L = light (feather edges are worn but not frayed or nicked);

M = moderate (fraying and perhaps some small nicks are obvious);

R = ragged (very worn edges, often the tips are worn off or shafts extend beyond the vane). Ventral feathers rarely show wear and are usually entered as F. Some studies may record molt and wear in separate fields. See Section 7.5.2., for suggestions on viewing ventral areas.

FAT (1). -- Subcutaneous fat deposits are checked for in the abdominal and furcular (the midventral depression just anterior to the breast musculature) areas. Express subjective amounts of fat as:

0 = none;

1 = a small amount of fat visible;

2 = moderate levels;

3 = bulging with fat.

See Ralph et al. 1993 for a more detailed system of expressing fat levels.

DORSAL (1). -- The feathers are separated by gentle blowing on the feathers on the dorsum from head to base of tail. Molt or wear is expressed as done for VENTRAL feather tracts.

BUFFYBACK (1). -- May be an indicator of immaturity. Dorsal feathers with light buffy edges, are designated with y = yes or s = some buffy. Otherwise n = no should be used.

PRIMARY (1). -- The newest sheathed or missing primary (p) feather is designated (valid numbers: 1-9; 10 is indicated by a zero; remember that p10 is typically replaced before p9). If there is no molt, wear on the tips should be noted as described under VENTRAL.

PRITIPS (1). -- This is a key character in separating some hummingbirds. If width of p1-p6 is about the same as p7-p10, enter the following: "=" (equal); if width of p1-p6 is not equal to p7-p10, "u" (unequal) is entered (Figs. 22 and 23).

PRIEMARG (1). -- A key character for *Archilochus* only. Nature of the tips of the inner primaries (p1- p6) are described as emarginate or rounded? Use "e" = emarginate; "r" = rounded (Fig. 24).

SECONDARY (1). -- Evaluated as for PRIMARY, valid numbers = 1-6, or indicate wear.

SECSHAP\_CA (1). -- A key character in *Calypte*. What is the shape of the tips of the secondaries? Use "e" if emarginate; "r" if rounded (see Baltosser 1987: 153).

RECTRICES (1). -- Five pairs of rectrices (r) characterize hummingbirds; r1s are in the center, r5s are the outer. The newest sheathed or missing r should be designated by number. If no molt exists, wear on the feather tips should be noted as described under VENTRAL. Valid numbers = 1-5 for molt or indicate wear.

R1RUFIOUS (2). -- A character used to determine sex of some *Selasphorus*. This is an estimate of the amount of rufous in r1, expressed as a percent of an all rufous pattern.

R5SHAPE (1). -- A character useful in determining the sex of immature *Archilochus* (Fig. 25). The shape of r5 is described as "p" for pointed or "r" for rounded.

BL\_INTOW (1). -- A useful character in determining the sex of immature *Calypte*. Does black enter the white in the tips of r5? Use "y" for yes; "n" for no (Fig. 26).

R5WIDTH (3). -- A useful character in identifying several species. The widest point of r5 near the tip is measured and recorded to the nearest 0.1 mm.

WEIGHT (3). -- Weight recorded to nearest 0.1 g.

\*AGE (1). -- Age codes are recorded after the appropriate age designation is determined. Use "0" = age unknown (a bird that cannot be placed in any of the year classes below. Except in cases during the nesting season where data were not recorded or were lost, only birds banded after the breeding season and before January 1 can be correctly coded "0". "4" should be used for a young bird incapable of sustained flight. After a young bird achieves sustained flight it becomes a "2" until December 31. "1" should be used for a bird known to have hatched before the calendar year of banding. "5" should be used for a bird known to have hatched in the calendar year preceding the year of banding and now in its second calendar year of life. Other age categories are not presently recognizable in hummingbirds.

\*SEX (1). -- Use "4" for male, "5" for female, and "0" for sex unknown

\*ALPHA (4). -- The alpha species codes are designated by the Banding Offices and can be found in the Bird Banding Manual. Banders should prepare a list of the alpha codes for species likely to be banded; this list should be part of the banding equipment.

\*DATE (8). -- Enter as month, day, year.

\*LOCATION (2). -- A numeric or alpha code should be designated for each banding site.

COMMENTS. -- This field should provide adequate space for entry of comments on unusual attributes, photo details, etc.

For those banders who use Microsoft Excel ® for their banding data the use of a template for data recording will streamline the process of importing data into Bandit for reporting. Refer to the link at the bottom of this BBL website page:

<http://www.pwrc.usgs.gov/BBL/resources/bandit/Documentation/index.cfm>